



FULL CONTROL BOARD MANUAL

https://www.bft-automation.com/grcodemanual/D814283

VIRGO BT B 20 KIT VIRGO BT B 20 KIT SLAVE



D814438 OADA0_01 20-06-24

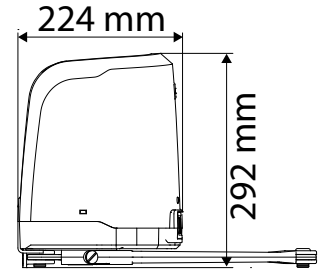
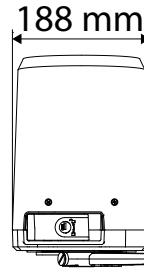
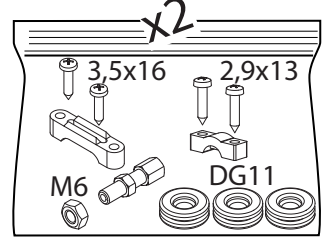
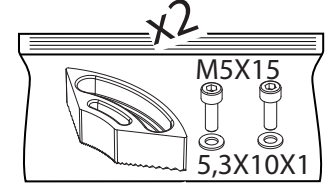
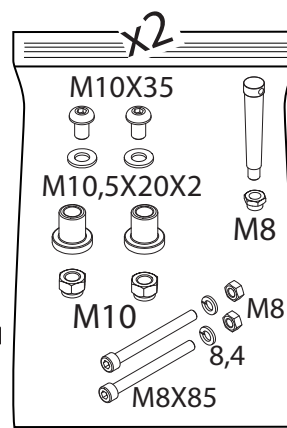
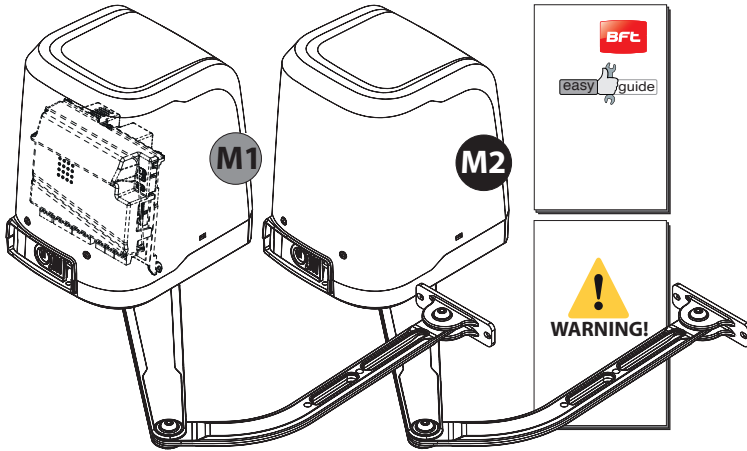

IT	Verifica la tua composizione nell'etichetta imballo.
EN	Check your composition on the packaging label
FR	Vérifiez votre composition sur l'étiquette d'emballage.
ES	Controla la composición de tu kit en la etiqueta del embalaje
DE	Überprüfen Sie Ihre Zusammenstellung auf dem Verpackungsetikett.
NL	Controleer uw samenstelling op het verpakingslabel.
PT	Verifique a composição no rótulo da embalagem
EL	Ελέγξτε τη σύνθεση του κιτ στην ετικέτα της συσκευασίας
PL	Prosimy sprawdzić zawartość zestawu na etykięcie opakowania"
RU	Проверьте комплектацию на этикетке упаковки.
CS	Zkontrolujte složení sady na štítku obalu.
TR	Ambalaj etiketindeki bileşiminizi kontrol edin
HR	Na etiketi provjerite sastav svojeg paketa
RO	Verificați-vă compoziția de pe eticheta ambalajului
AR	تحقق من التركيبة لي ماصق العبوة

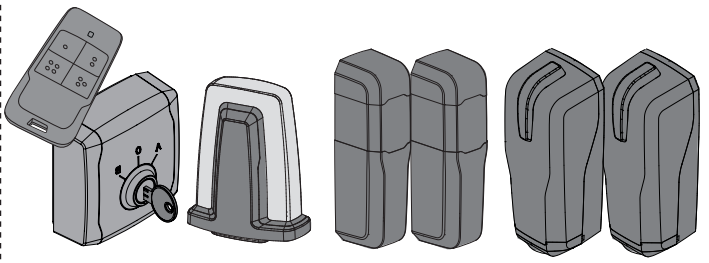

	M1	M2 SLAVE
	220-230 V 50/60 Hz	/
P stand-by	0,48 W	/
Pmax	110 W	40 W
	433,92 MHz	
IP	44	
	-20°C / +60°C	
cycles/h	30	
	<70 dBA	
Speed max	6°/s	

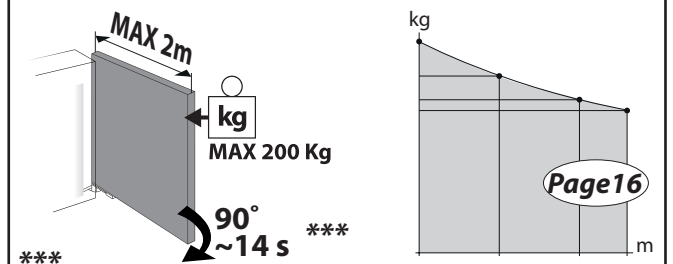

*** IT: Tempo indicativo misurato senza rallentamenti (anta massima e peso massimo).
 EN: Indicative time measured without slowdowns (maximum door and maximum weight).
 FR: Temps indicatif mesuré sans ralentissements (vantail maximum et poids maximum).
 DE: Gemessene Richtzeit ohne Abbremsen (maximaler Flügel und maximales Gewicht).
 ES: Tiempo orientativo medido sin ralentizaciones (puerta máxima y peso máximo).
 NL: Indicatieve tijd gemeten zonder vertragingen (maximale vleugel en maximaal gewicht).
 PT: Tempo indicativo medido sem desacelerações (porta máxima e peso máximo).
 GR: Ενδεικτικός χρόνος μετρημένος χωρίς επιβραδύνσεις (μέγιστο φύλλο και μέγιστο βάρος).
 PL: Orientacyjny czas mierzony bez spowolnień (maksymalne skrzydło i maksymalna waga).
 RU: Ориентировочное время, измеренное без замедлений (максимальная створка и максимальный вес).
 CZ: Orientační čas měřený bez zpomalení (maximální křídlo a maximální hmotnost).
 TR: Yavaşlama olmadan ölçülen gösterge süre (maksimum kanat ve maksimum ağırlık).
 HR: Indikativno vrijeme izmjereno bez usporavanja (maksimalni list i maksimalna težina).
 RO: Timp orientativ măsurat fără încetiniri (frunză maximă și greutate maximă).
 AR: تم قياس الوقت الاسترشادي بدون تباطؤ (الحد الأقصى للباب والوزن الأقصى).

Example

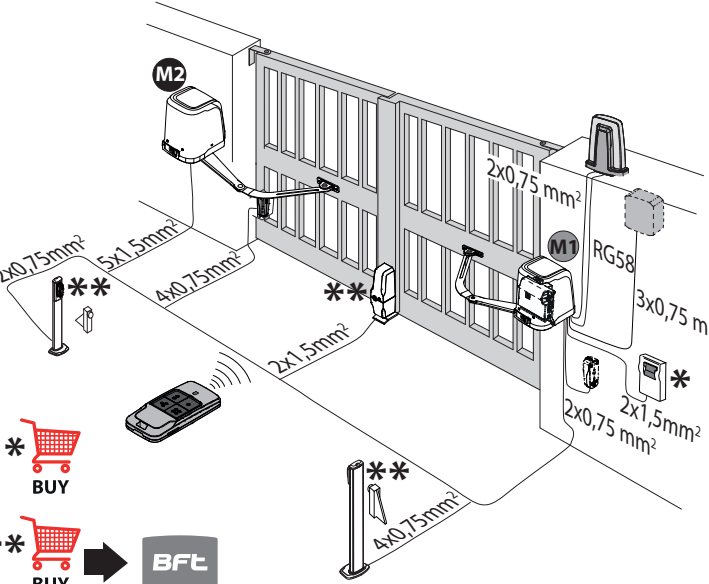

BUY



BUY



Page 16

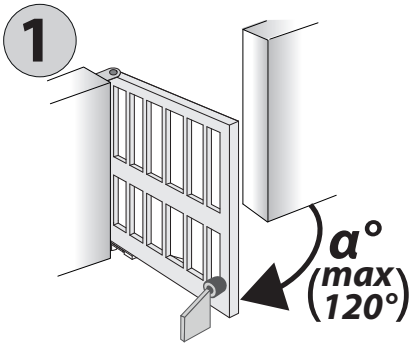

		A mm												
		128,5	140	150	160	170	180	190	200	210	220	230	240	250
B mm	30	90°	92°	95°	100°	102°	105°	107°	110°	112°	115°	118°	120°	
	40	90°	92°	95°	100°	102°	105°	107°	110°	112°	115°	115°	118°	
	50	90°	92°	95°	100°	102°	105°	107°	110°	110°	110°	115°	115°	
	60	90°	92°	95°	100°	102°	105°	107°	107°	110°	110°	115°	115°	
	70	90°	92°	95°	97°	100°	102°	107°	107°	110°	110°	112°	115°	
	80	90°	92°	95°	97°	100°	102°	105°	107°	107°	110°	110°	112°	
	90	90°	92°	95°	97°	100°	102°	105°	107°	107°	110°	112°	112°	
	100	90°	92°	95°	97°	100°	102°	105°	105°	107°	110°	112°	112°	
	110	90°	92°	95°	97°	100°	102°	102°	105°	107°	107°	110°	112°	
	120	90°	92°	95°	97°	100°	100°	102°	105°	107°	107°	110°	112°	
	130	90°	92°	95°	97°	100°	100°	102°	105°	105°	107°	110°		
	140	90°	92°	92°	97°	97°	100°	102°	105°	105°	107°			
	150	90°	90°	92°	97°	97°	100°	102°	102°	105°				
	160	90°	90°	92°	95°	97°	100°	100°	102°					
	170	90°	90°	92°	95°	97°	100°	100°						
180	90°	90°	92°	95°	97°	100°								
190	90°	90°	92°	95°	97°									
200	90°	90°	92°	95°										
210	90°	90°	92°	95°										
220	90°	90°	92°											
230	90°	90°												
235	90°													

α°

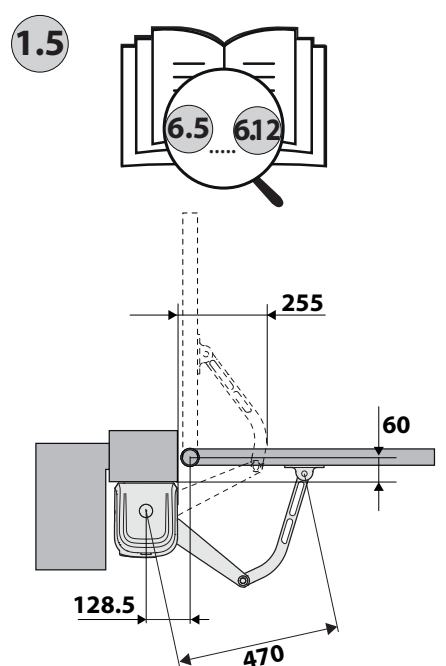
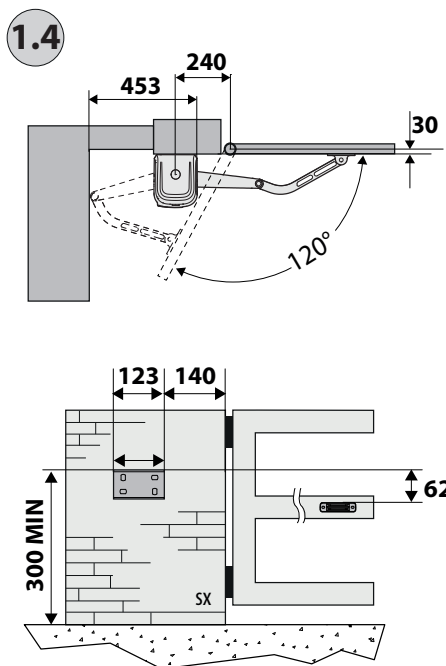
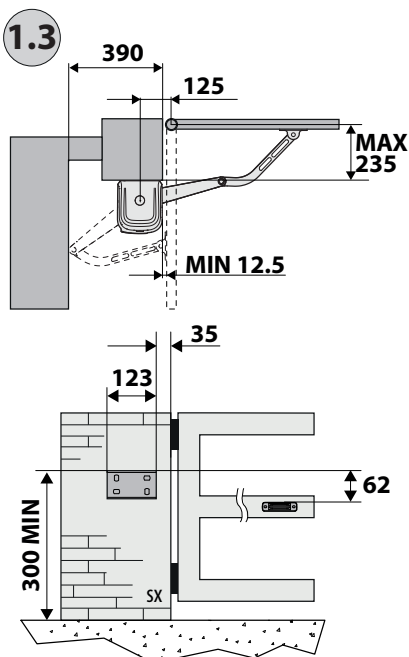
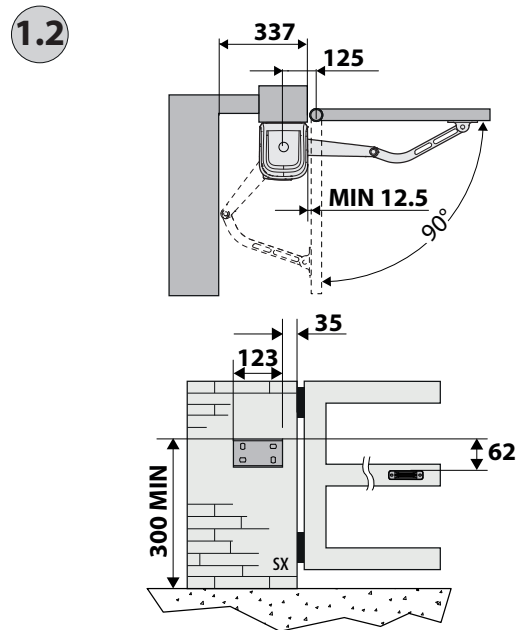
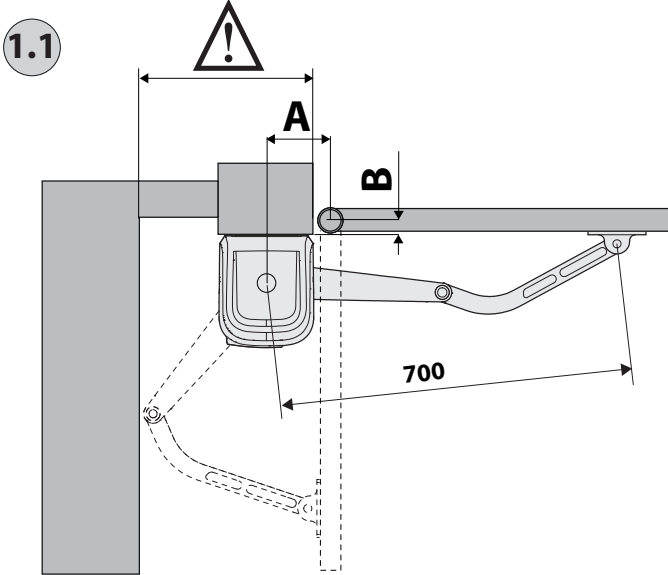

2

2.1

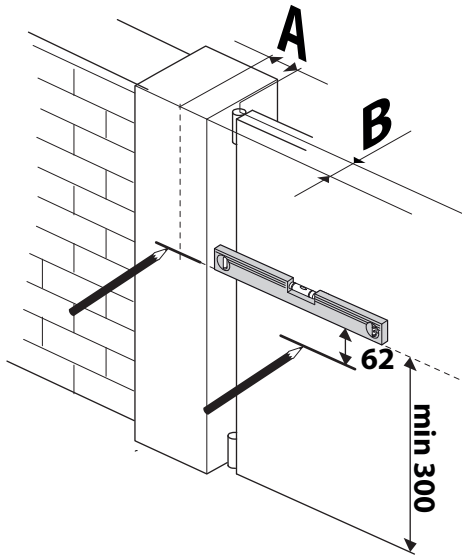

2.2

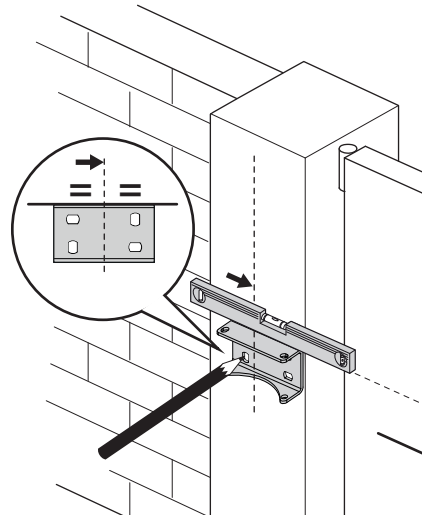

2.3

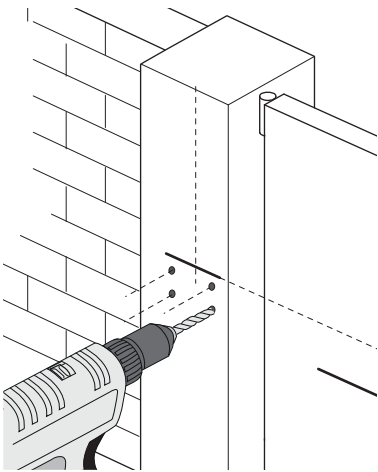

2.4

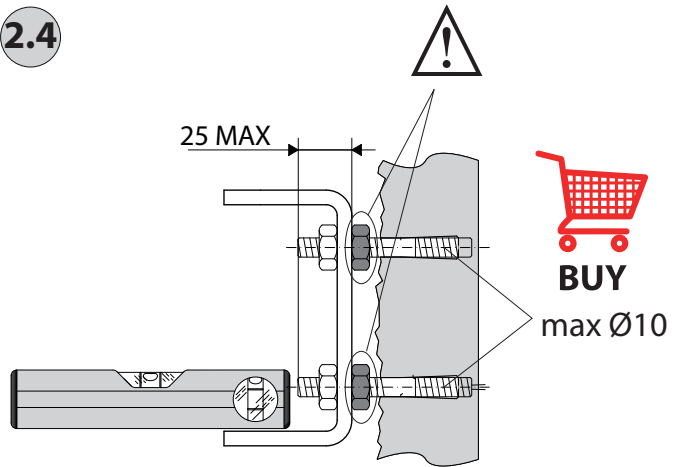

3

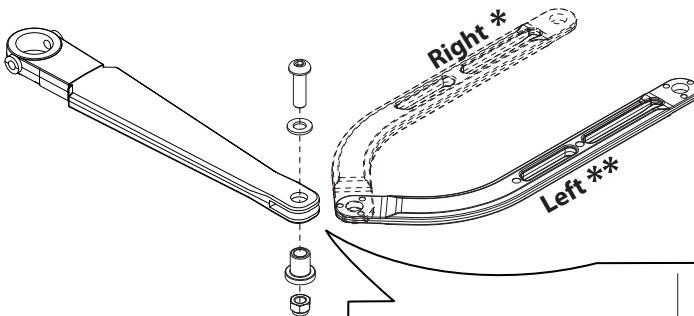
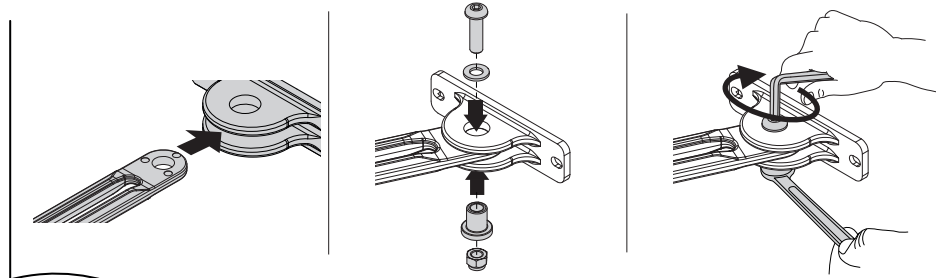

- | | |
|----------|-------------|
| * Destra | ** Sinistra |
| Right | Left |
| Droite | Gauche |
| Rechts | Links |
| Derecha | Izquierda |
| Rechts | Links |
| Direita | Esquerda |
| Δεξιά | Αριστερά |
| Prawa | Lewa |
| Право | Лево |
| Vpravo | Vlevo |
| Sağ | Sol |
| Desno | Lijevo |
| Dreapta | Stânga |
| اليمين | اليسار |

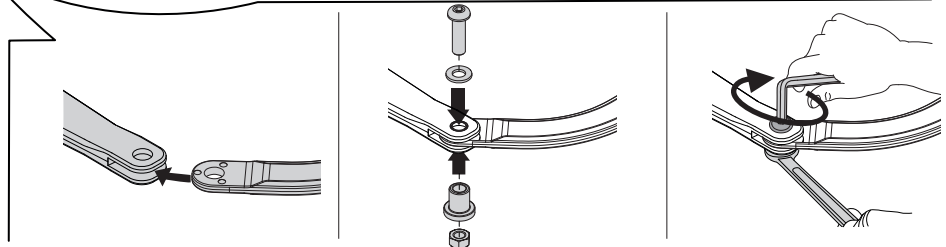

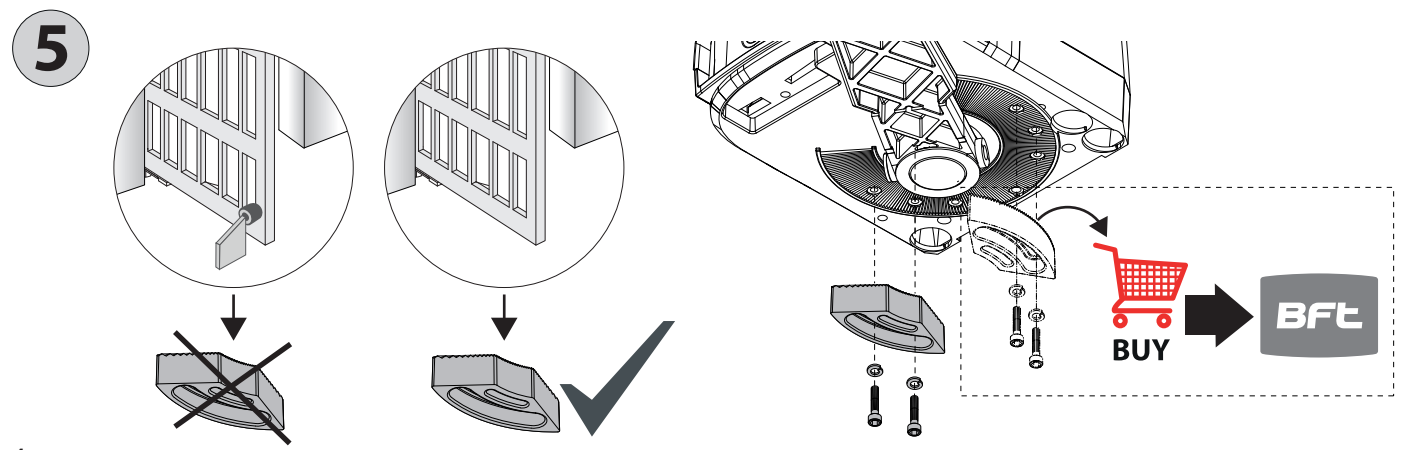
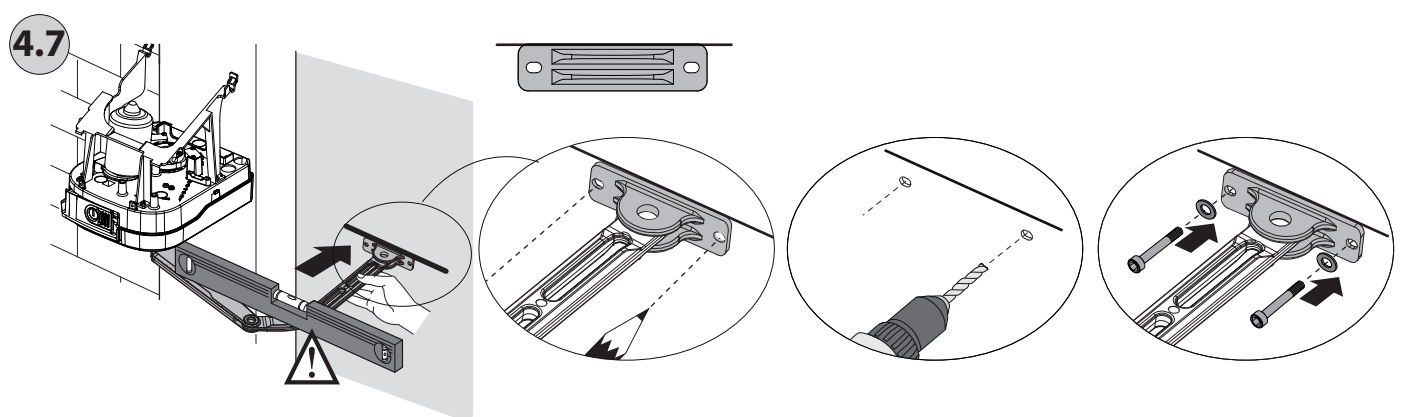
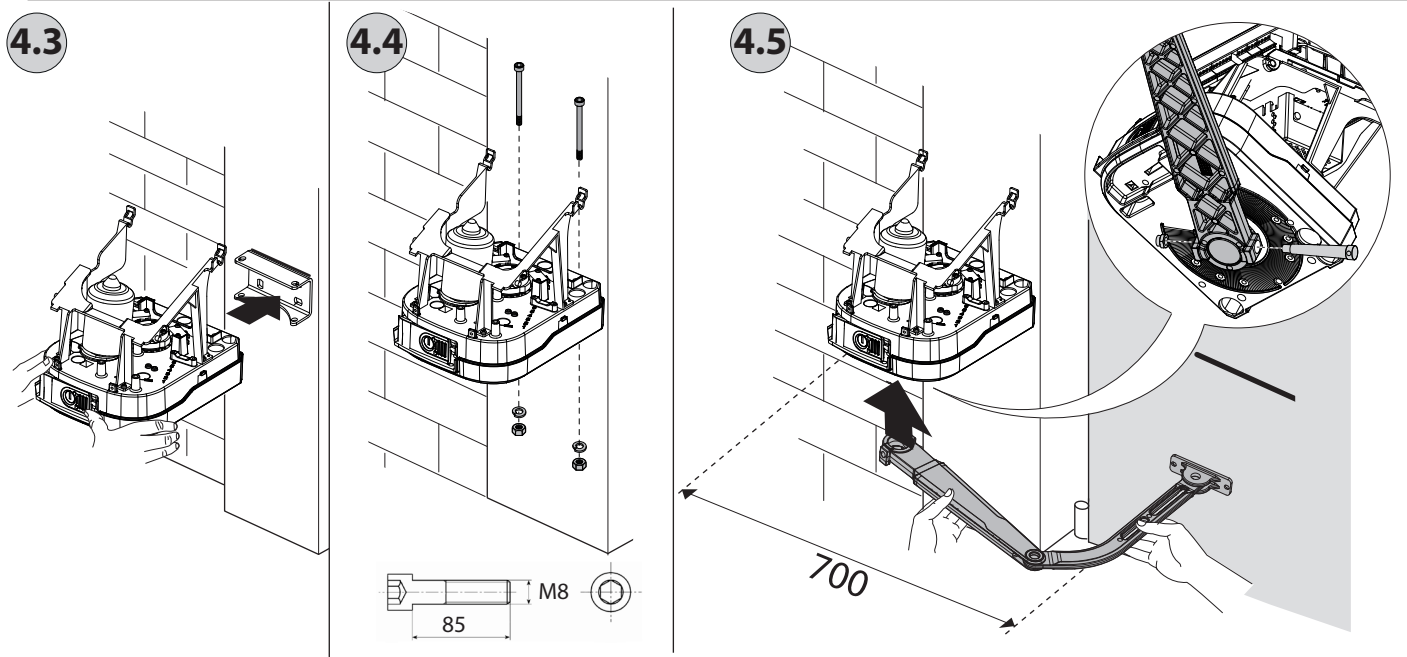
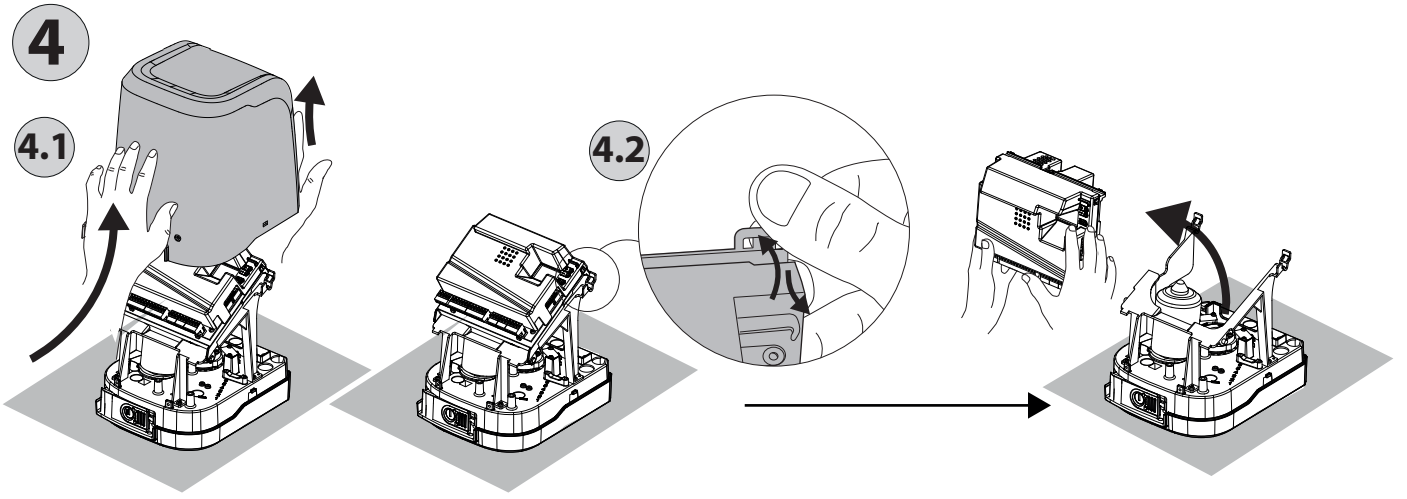

6

REGOLAZIONE FINECORSA, LIMIT DEVICE ADJUSTMENT,
 RÉGLAGE DES FINS DE COURSE, EINSTELLUNG DES ENDSCHALTERS,
 REGULACIÓN DEL FIN DE CARRERA, AFSTELLING EINDAANSLAG,
 REGULAÇÃO FIM DE CURSO, ΡΥΘΜΙΣΗ ΤΕΡΜΑΤΙΚΩΝ,
 REGULACJA WYŁĄCZNIKÓW KRAŃCOWYCH
 РЕГУЛИРОВКА КОНЦЕВОГО ВЫКЛЮЧАТЕЛЯ, SEŘÍZENÍ KONCOVÉHO SPÍNAČE,
 LİMİT SVİCİNİN AYARLANMASI, PODEŠAVANJE GRANIČNOG PREKIDAČA,
 SETAREA COMUTATORULUI DE LİMİTĂ, الحد من تعديل التبديل

 **example 6.4**

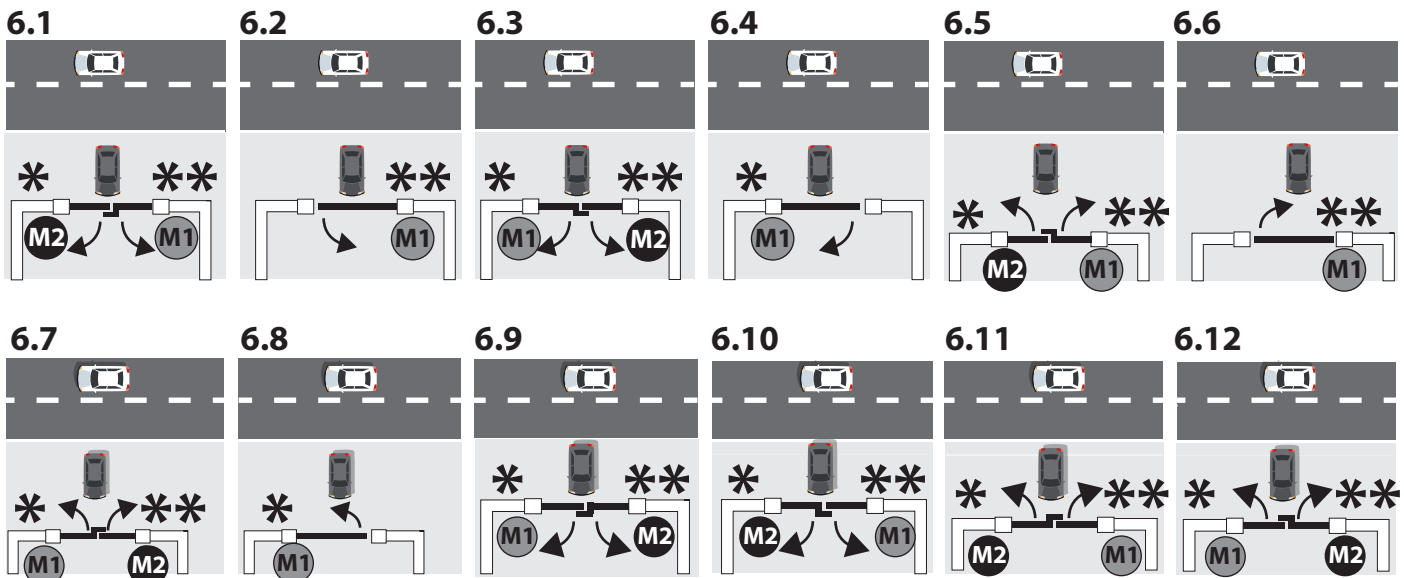
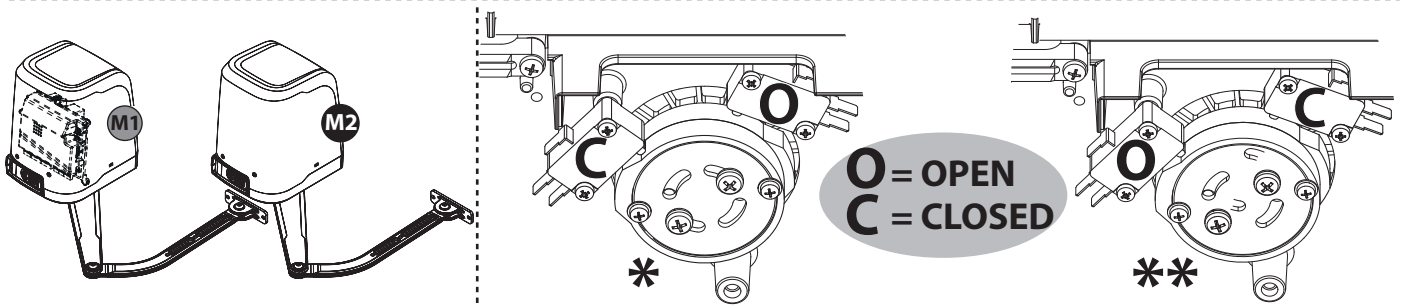
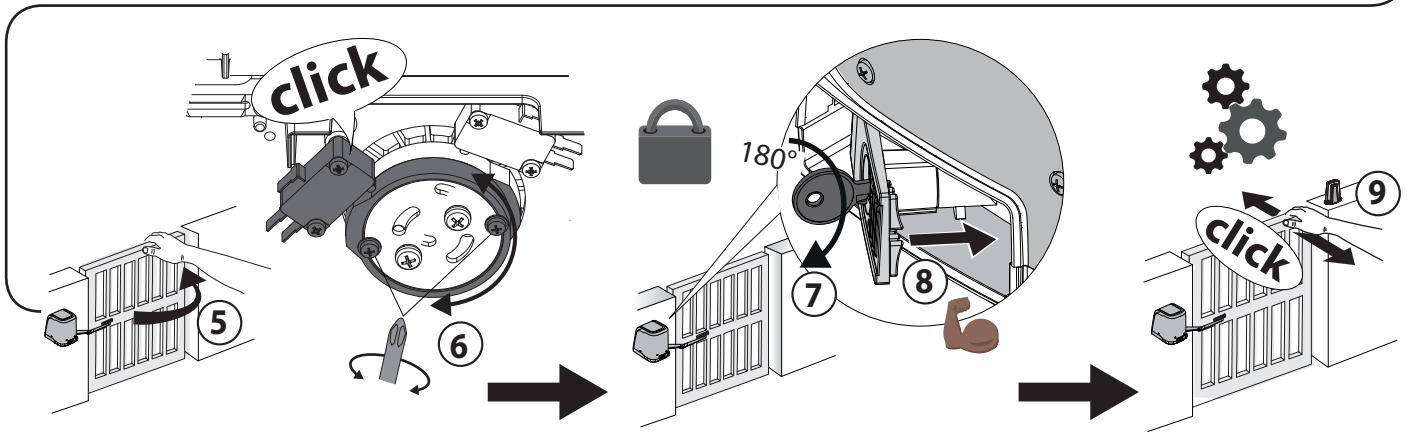
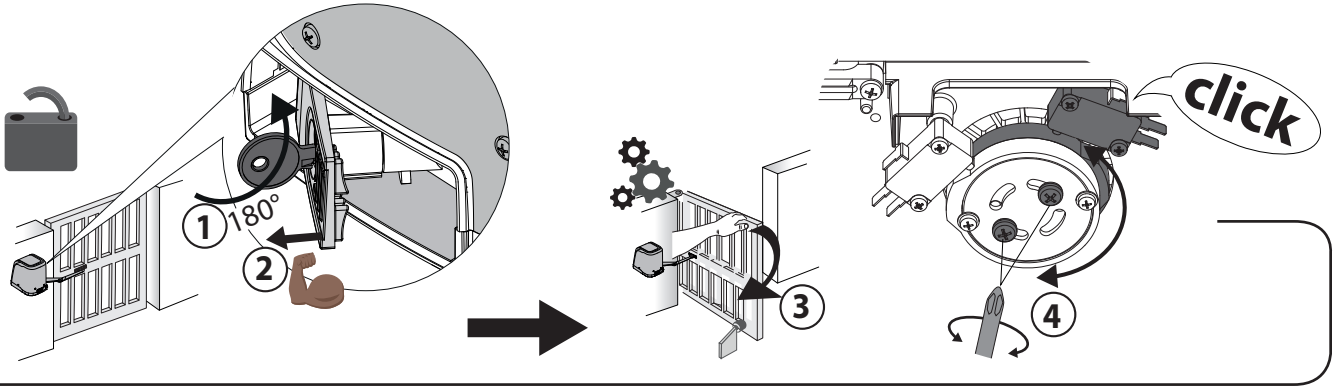
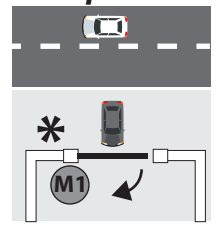

7

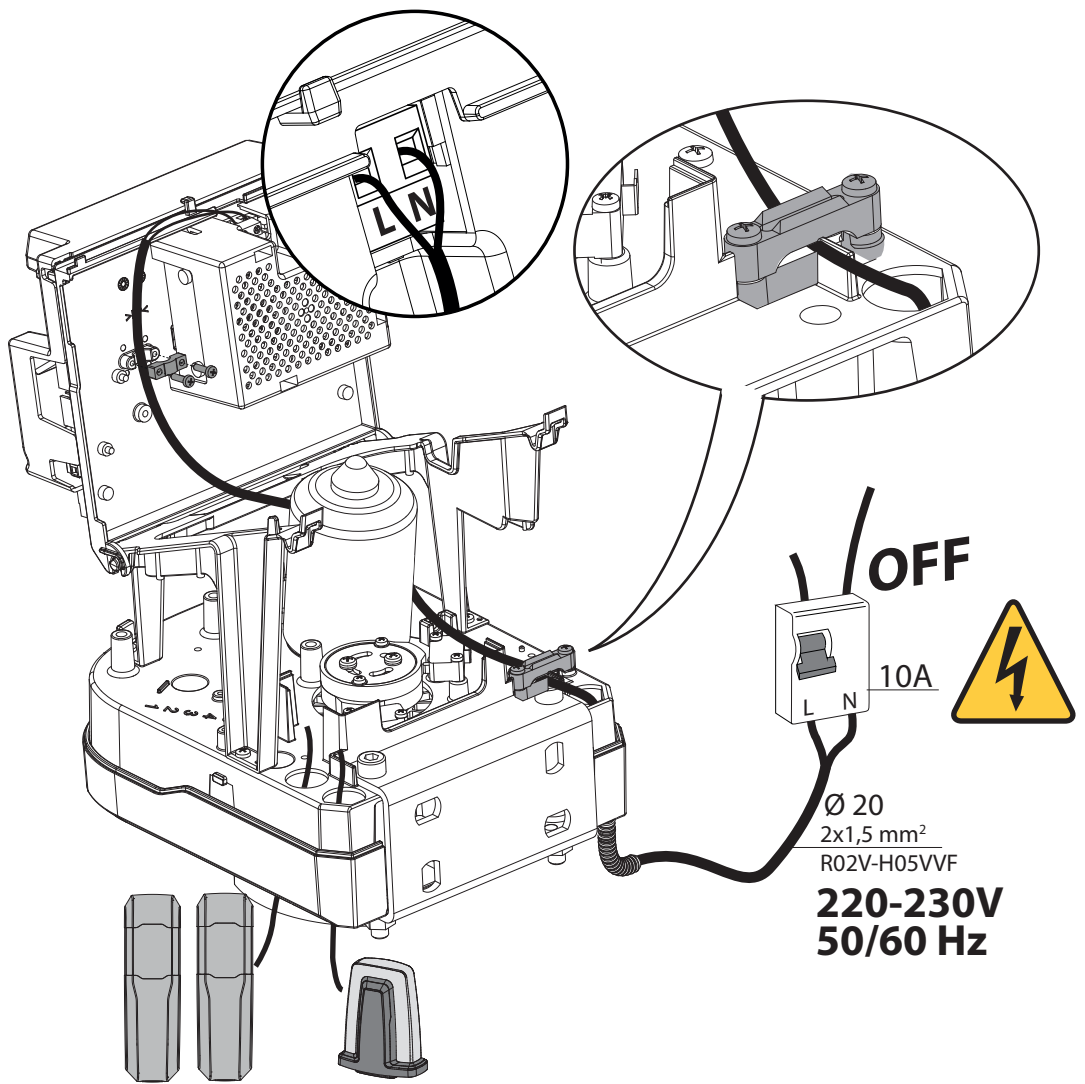
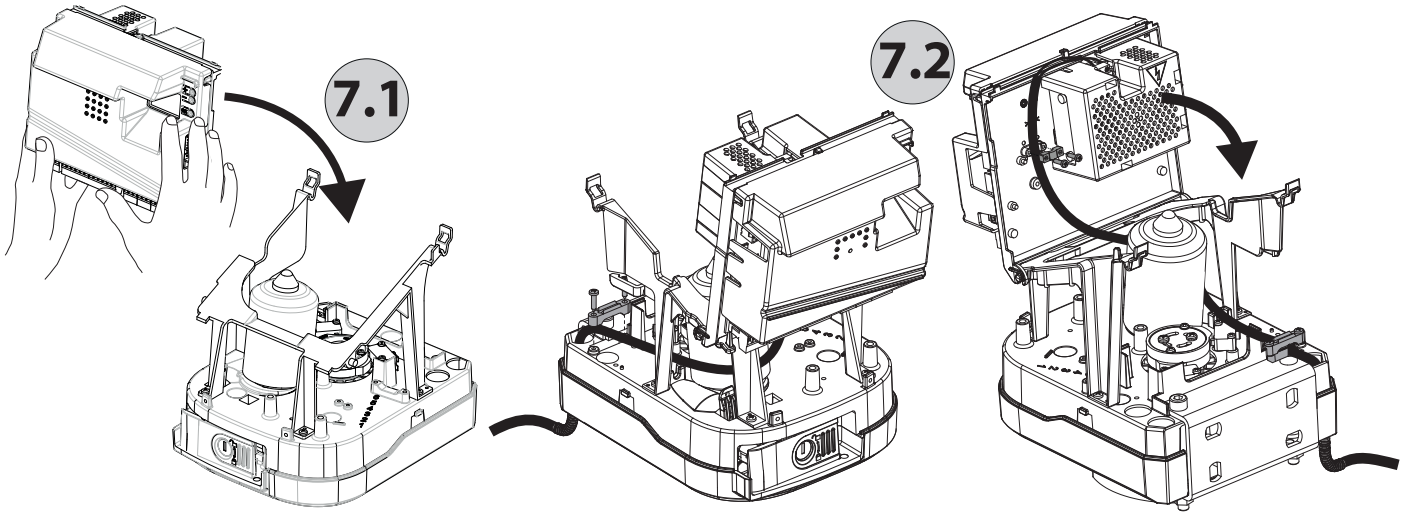

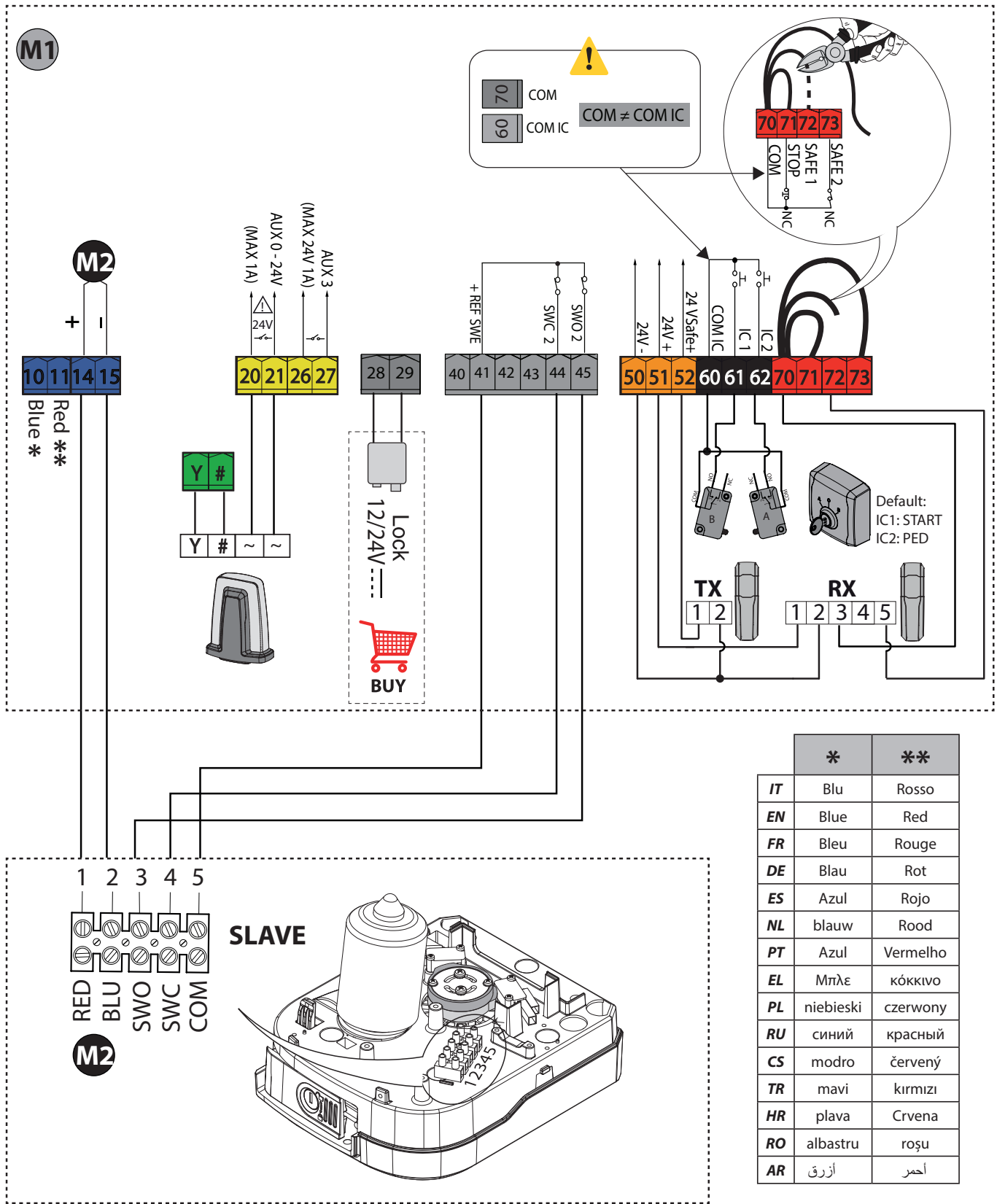

	*	**
IT	Blu	Rosso
EN	Blue	Red
FR	Bleu	Rouge
DE	Blau	Rot
ES	Azul	Rojo
NL	blauw	Rood
PT	Azul	Vermelho
EL	Μπλε	κόκκινο
PL	niebieski	czerwony
RU	синий	красный
CS	modro	červený
TR	mavi	kırmızı
HR	plava	Crvena
RO	albastru	roșu
AR	أزرق	أحمر

8

**MENÙ SEMPLIFICATO - SIMPLIFIED MENU - MENU SIMPLIFIÉ -
VEREINFACHTES MENÜ - MENÙ SEMPLIFICADO - VEREENVUODIGD MENU -
MENU PROGRAMAÇÃO INSTALAÇÃO - ΜΕΝΟΥ ΡΥΘΜΙΣΗΣ ΕΓΚΑΤΑΣΤΑΣΗΣ -
MENU USTAWIEŃ INSTALACJI - МЕНЮ УСТАНОВКИ ОБОРУДОВАНИЯ - MENU PRO NASTAVENÍ
ZAŘÍZENÍ - TESİSİ AYARLAMA MENÜSÜ -
ПОЈЕДНОСТАВЉЕНИ ИЗБОРНИК - ZJEDNODUŠENÉ MENU - القائمة المبسطة**

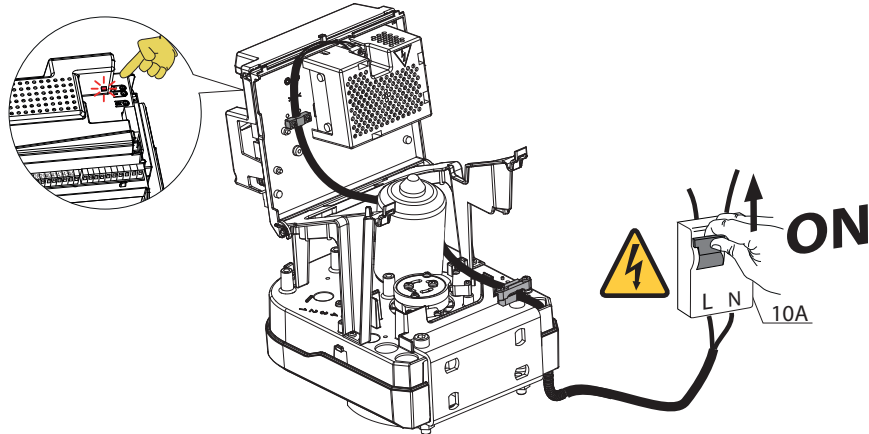

**LEGENDA - LEGENDE - LEGEND - LEYENDA - ΥΠΟΜΝΗΜΑ -
УСЛОВНЫЕ ОБОЗНАЧЕНИЯ - ANLAMLAR - أسطورة**

C

IT	Cancello chiuso
EN	Gate closed
FR	portail fermé
ES	puerta cerrada
DE	Tor geschlossen
NL	hek gesloten
PT	portão fechado
EL	πύλη κλειστή
PL	brama zamknięta
RU	закрытые ворота
CS	brána zavřena
TR	kapı kapalı
HR	Vrata zatvorena
RO	Barieră închisă
	البوابة مغلقة AR

PrG

IT	Salvataggio in corso
EN	Saving
FR	sauvegarde en cours
ES	copia de seguridad en curso
DE	Backup läuft
NL	back-up wordt uitgevoerd
PT	backup em curso
EL	δημιουργία αντιγράφων ασφαλείας σε εξέλιξη
PL	wykonywanie kopii zapasowej w toku
RU	выполняется резервное копирование
CS	probíhá zálohování
TR	yedekleme devam ediyor
HR	Spremanje
RO	Salvare
	حفظ AR

O

IT	Cancello aperto
EN	Gate opened
FR	portail ouvert
ES	puerta abierta
DE	Tor offen
NL	hek geopend
PT	portão aberto
EL	πύλη ανοιχτή
PL	brama otwarta
RU	открытые ворота
CS	brána otevřena
TR	kapı açık
HR	Vrata otvorena
RO	Barieră deschisă
	البوابة مفتوحة AR



IT	Azione da fare rapidamente
EN	To do quickly
FR	action à faire rapidement
ES	la acción se debe realizar rápidamente
DE	Maßnahme schnell durchzuführen
NL	moet snel worden uitgevoerd
PT	ação a executar rapidamente
EL	ενέργεια που πρέπει να γίνει γρήγορα
PL	działania, które należy podjąć szybko
RU	быстро выполняемая операция
CS	akce, která má být provedena rychle
TR	hızlı bir şekilde gerçekleştirilecek eylem
HR	Brzo učiniti
RO	A se efectua rapid
	القيام بسرعة AR

Display in italiano

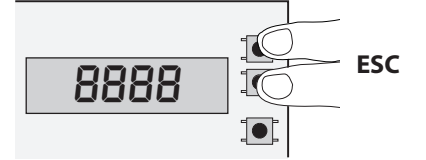
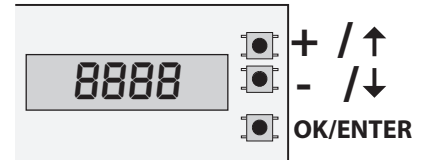
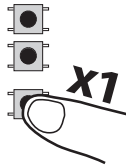

(IT) Lingua - (PT) Língua

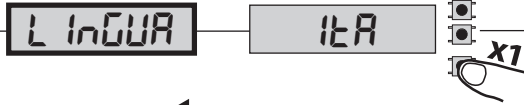

(IT) Tipo motore - (PT) Tipo de motor

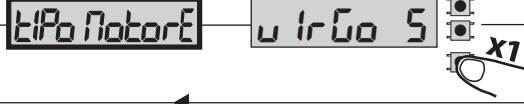

(IT) Numero motori - (PT) Número de motores

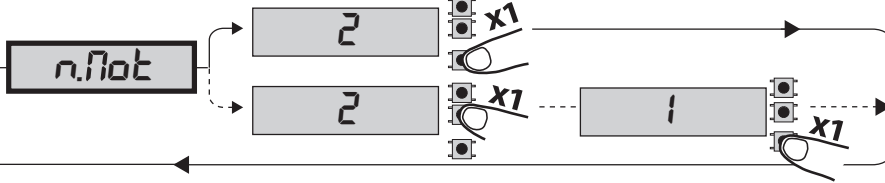

(IT) Direzione - (PT) Direção



(IT) Personalizzazione - (PT) Personalização

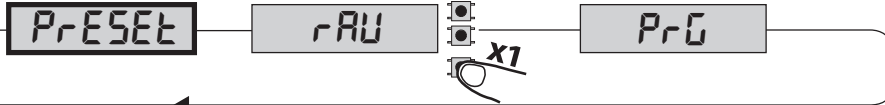

(IT) Memorizzazione dei telecomandi
(PT) Memorização dos comandos por rádio

IT Ripetere l'operazione se ci sono altri telecomandi
PT Repetir a operação se houver outros comandos por rádio

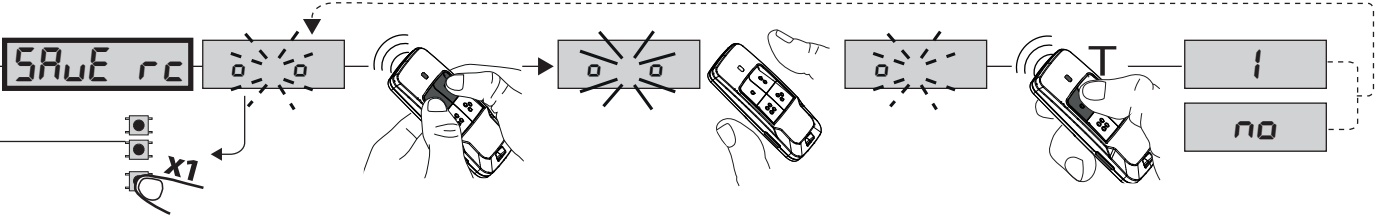

(IT) Regolazione finecorsa - (PT) Regulación de final de carrera



(IT) Regolazione automatico della forza - (PT) Regulação automática da força

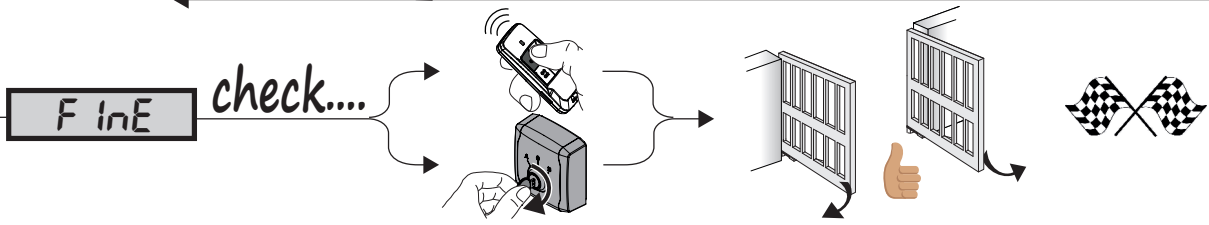
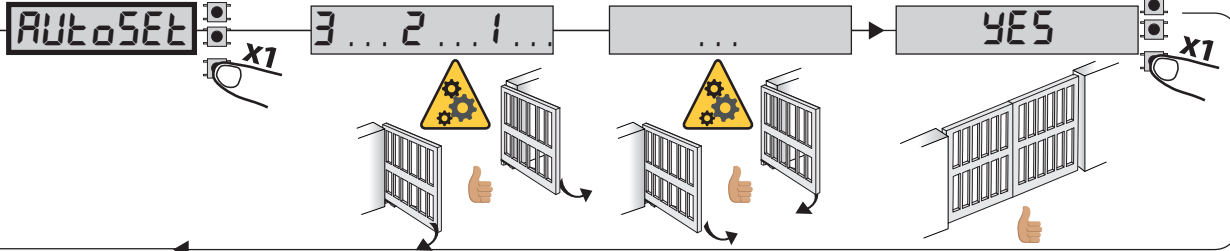

Display in English

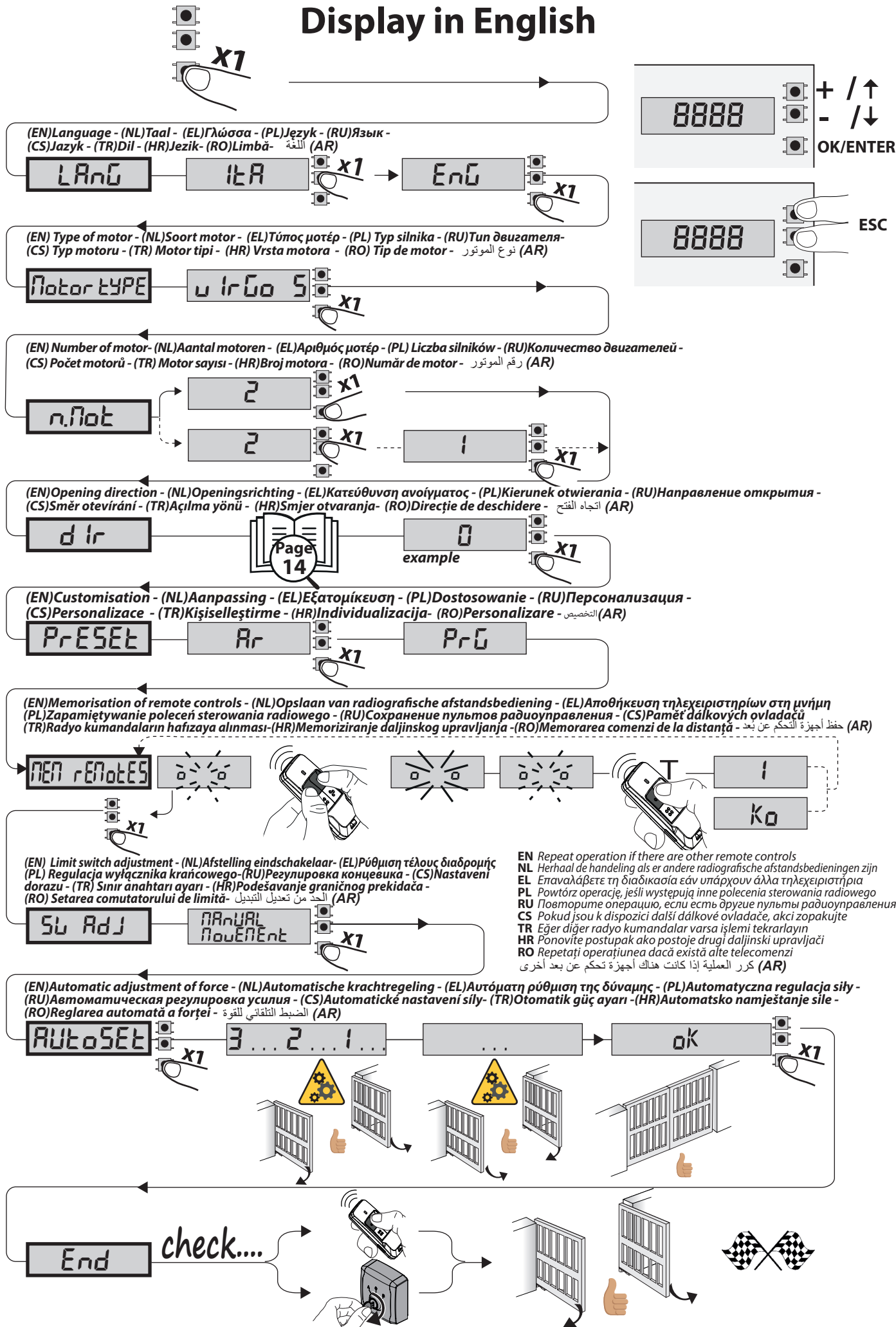

EN Repeat operation if there are other remote controls
NL Herhaal de handeling als er andere radiografische afstandsbedieningen zijn
EL Επαναλάβετε τη διαδικασία εάν υπάρχουν άλλα τηλεχειριστήρια
PL Powtórz operację, jeśli występują inne polecenia sterowania radiowego
RU Повторите операцию, если есть другие пульты радиоуправления
CS Pokud jsou k dispozici další dálkové ovladače, akci zopakujte
TR Eğer diğer radyo kumandalar varsa işlemi tekrarlayın
HR Ponovite postupak ako postoje drugi daljinski upravljači
RO Repetați operațiunea dacă există alte telecomenzi
(AR) كرر العملية إذا كانت هناك أجهزة تحكم عن بعد أخرى

Afficheur en français

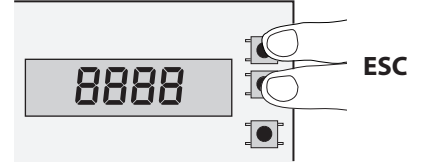
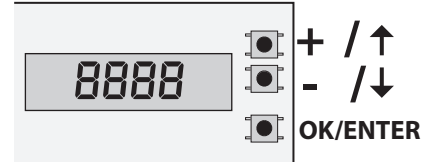
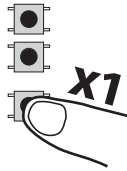

Langue

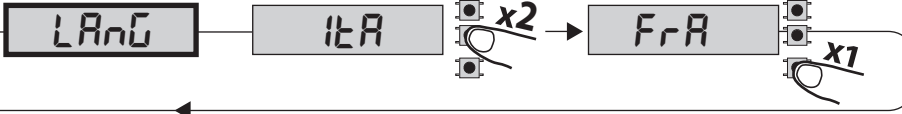

Type de moteur

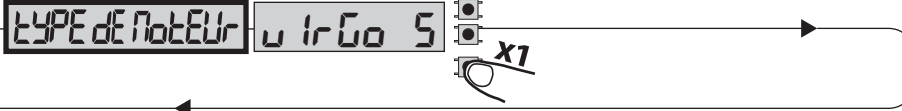

Nombre de moteurs

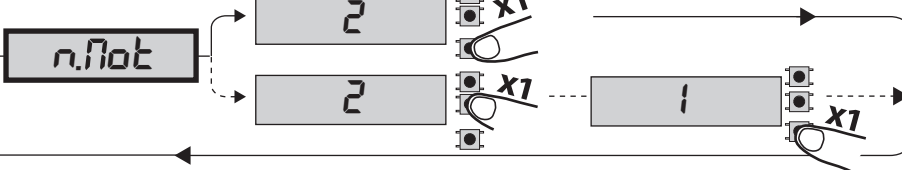

Direction d'ouverture



Personnalisation

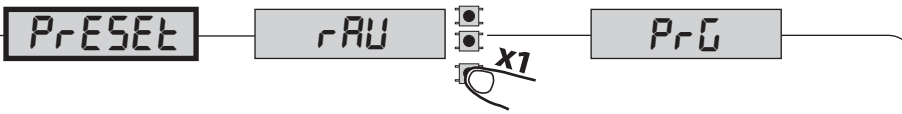

Mémorisation des télécommandes

Répète l'opération si d'autres télécommandes

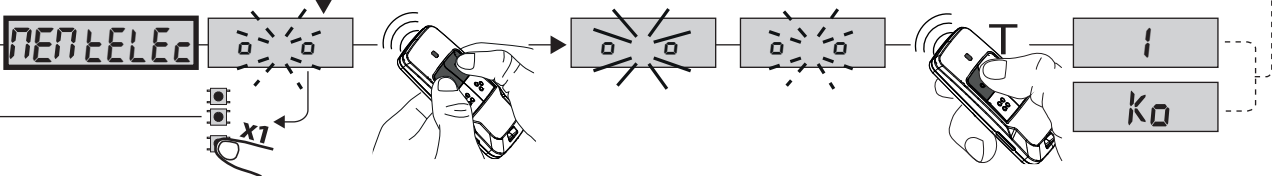

Réglage des fins de course



Réglage automatique de la force

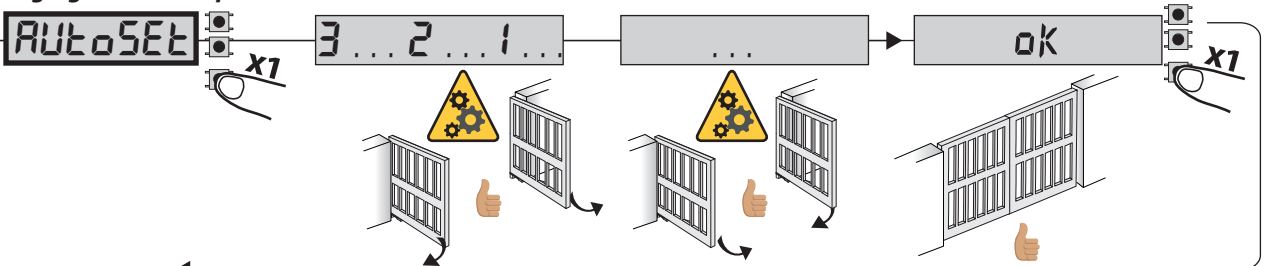

Fin check....

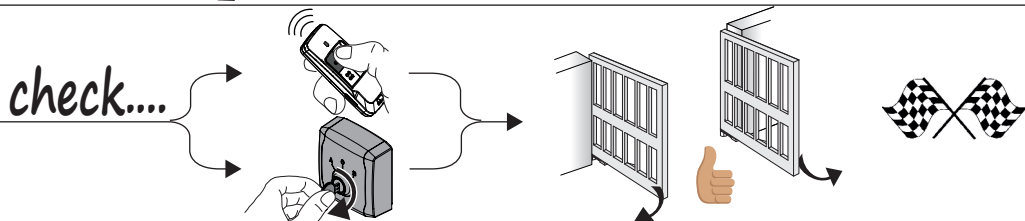

Menú en español

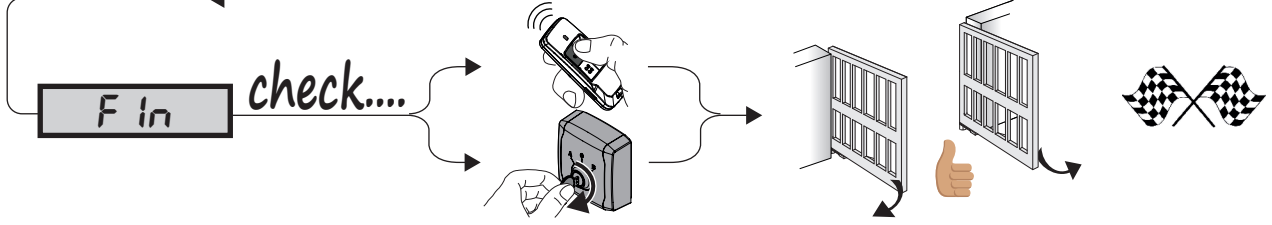
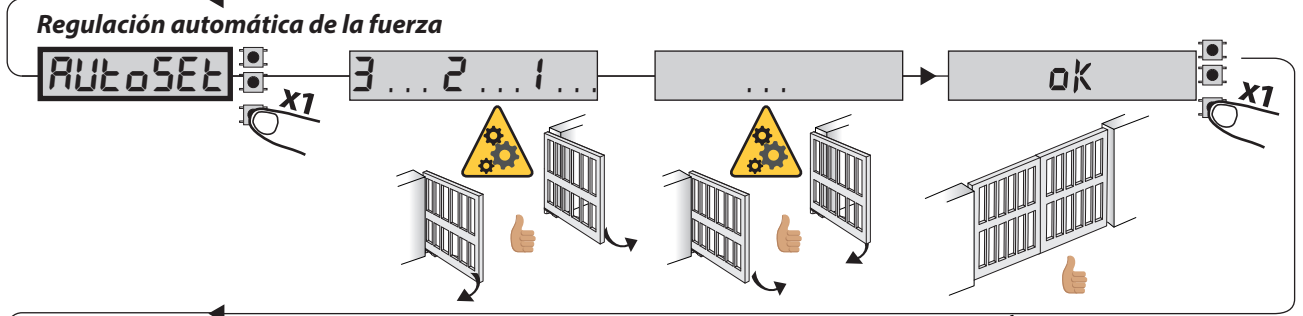
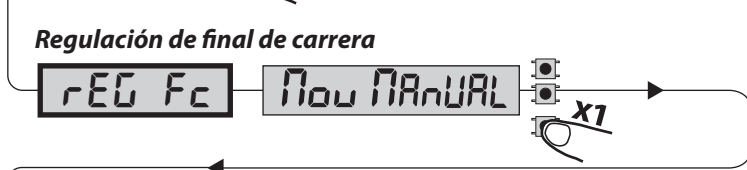
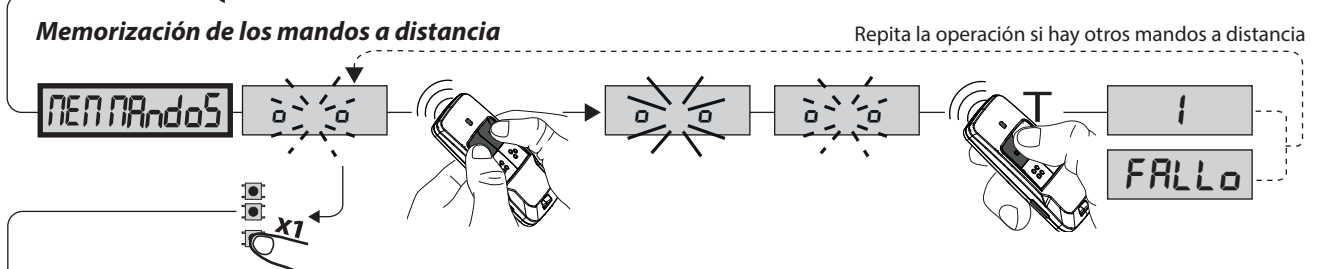
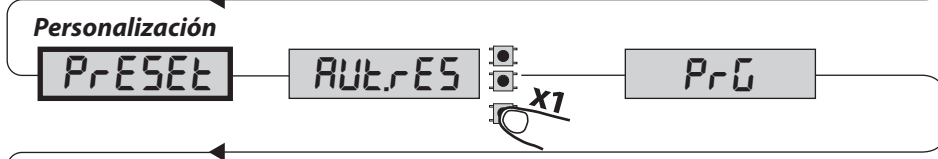
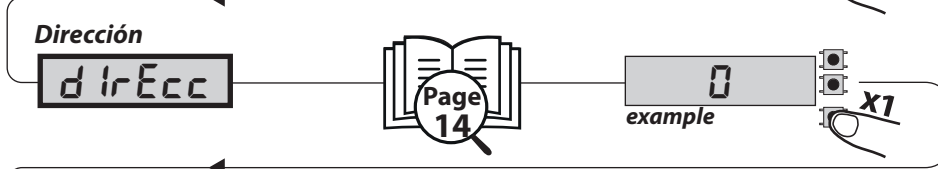
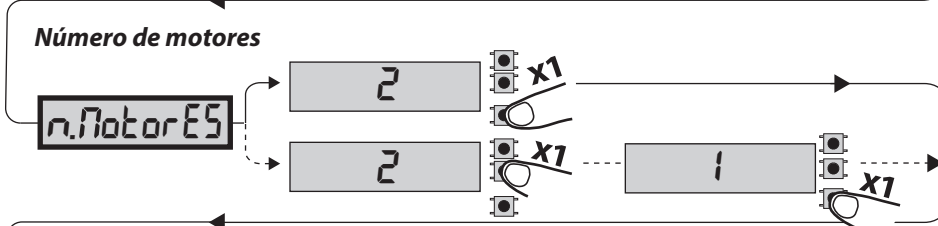
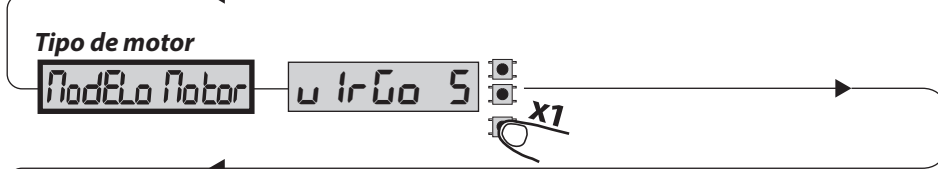
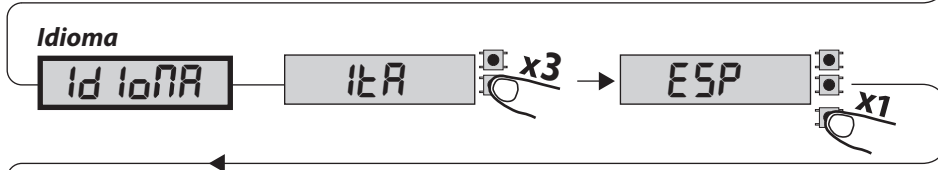
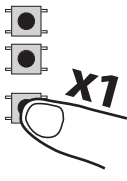
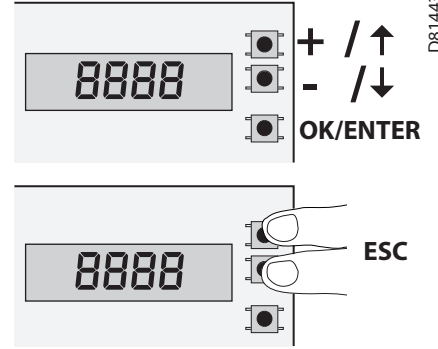

Auswahlmenü auf Deutsch

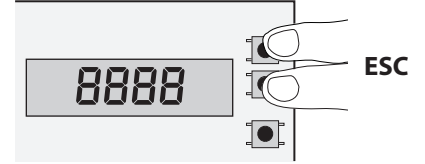
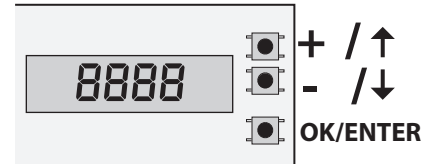
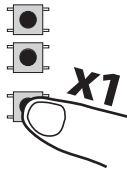

Sprache

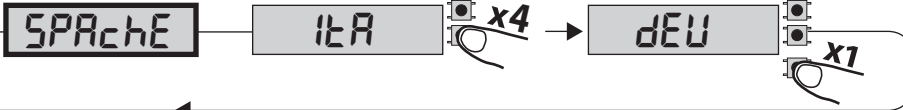

Motortyp

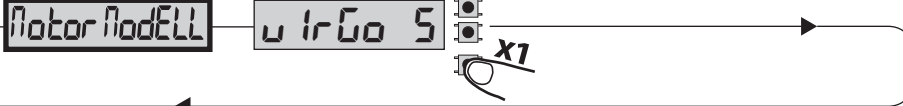

Anzahl der Motoren

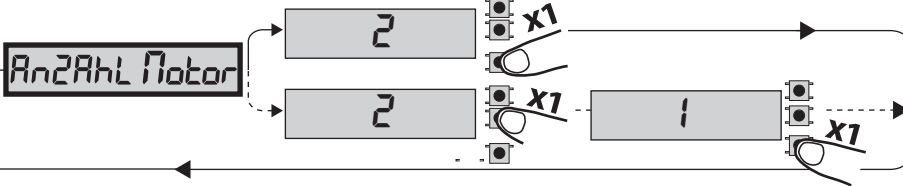

Öffnungsrichtung



Personalisierung

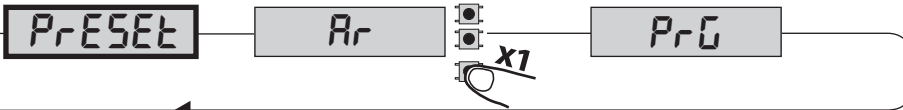

Speicherung der Fernbedienungen

Wiederholen Sie den Vorgang, wenn weitere Fernbedienungen vorhanden sind

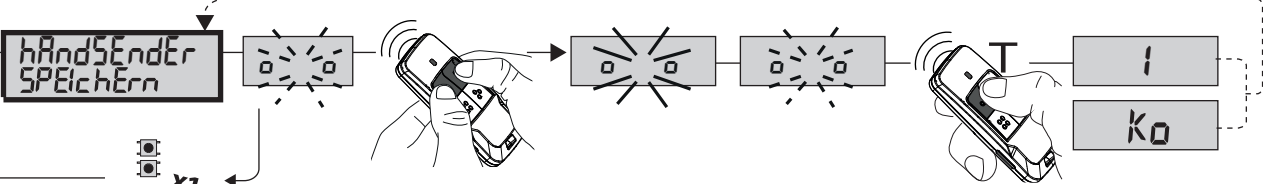

Einstellung des Endschalters



Speicherung der Fernbedienungen

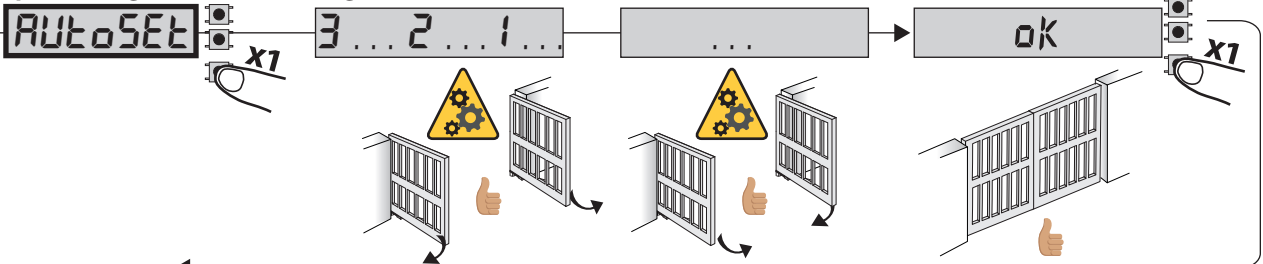

EndE check....

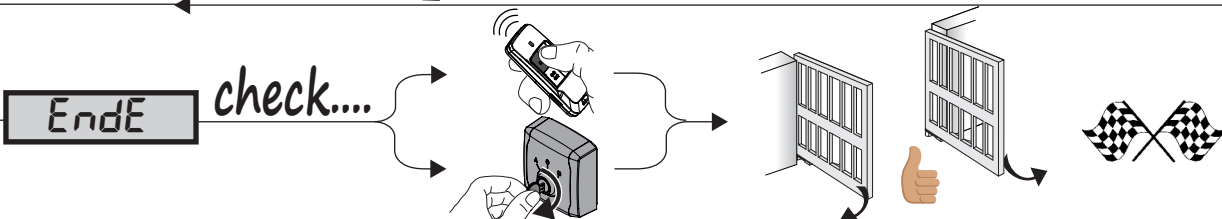

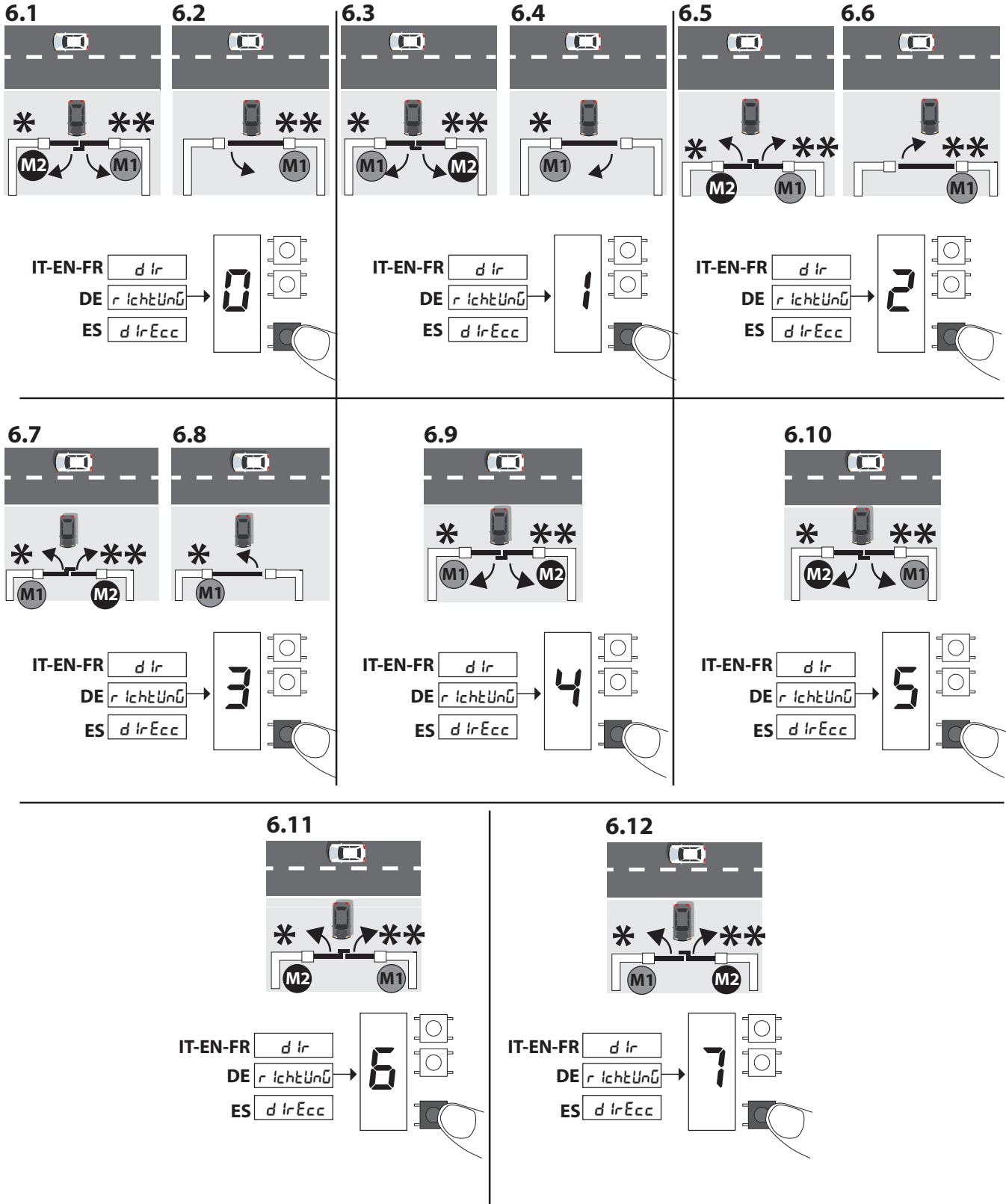

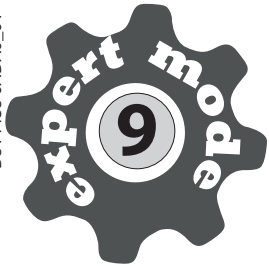

tcA

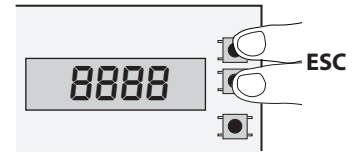
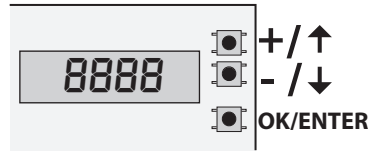

LEGENDA - LEGENDE - LEGEND - LEYENDA - ΥΠΟΜΝΗΜΑ - LEGANDA - LEZANTA - УСЛОВНЫЕ ОБОЗНАЧЕНИЯ - VYSVĚTLIVKY - ANLAMLAR - LEGENDÄ - أسطورة



(IT)Premere 4 volte rapidamente sul tasto OK - (EN) Press the OK button 4 times in quick succession - (FR)Appuyer 4 fois rapidement sur la touche OK
(ES)Pulse rápidamente el botón OK 4 veces - (DE)Drücken Sie 4 Mal schnell die Taste OK - (NL)Druk 4 keer snel op de knop OK
(PT) Premir rapidamente no botão OK 4 vezes - (EL)Πατήστε γρήγορα το κουμπί OK 4 φορές - (PL)Naciśnij szybko przycisk OK 4 razy (RU)Быстро нажмите кнопку OK 4 раза - (CS)Stiskněte tlačítko OK 4krát v rychlém sledu - (TR)4 kez hızlı bir şekilde OK düğmesine basın
(HR) Tipku OK redu brzo pritisnite 4 puta zaredom.-(RO) Apăsăți butonul OK de 4 ori în succesiune rapidă - (AR) اضغط على زر موافق 4 مرات في تعاقب سريع



(IT)premere finché compare il parametro desiderato - (EN) press until the desired parameter appears - (FR)appuyer jusqu'à voir le paramètre désiré
(ES)Pulse hasta que aparezca el parámetro deseado - (DE)drücken, bis der gewünschte Parameter erscheint - (NL)druk tot de gewenste parameter verschijnt
(PT) premir até encontrar o parâmetro desejado - (EL)πατήστε μέχρι να εμφανιστεί η επιθυμητή παράμετρος
(PL)naciskaj do momentu pojawienia się żadanego parametru - (RU)удерживайте до появления желаемого параметра
(CS)tiskněte, dokud se nezobrazí požadovaný parametr - (TR)istenen parametre görülene kadar basın -(HR) pritišćite sve dok se ne pojavi željeni parametar - (RO) apăsați până când apare parametrul dorit - (AR) اضغط حتى تظهر المعلمة المطلوبة

PrG

(IT)Programmazione - (EN) Programming - (FR)Sauvegarde en cours - (ES)Copia de seguridad en curso - (DE)Backup läuft - (NL)back-up wordt uitgevoerd
(PT) backup em curso - (EL)δημιουργία αντιγράφων ασφαλείας σε εξέλιξη - (PL>wykonywanie kopii zapasowej w toku - (RU)выполняется резервное копирование - (CS)probíhá zálohování - (TR>yedekleme devam ediyor - (HR) Programiranje - (RO) Programarea - (AR) برمجة

IT	Voglio impostare il tempo di chiusura automatica	DE	Ich möchte die Zeit für die automatische Schließung einstellen	PL	Chcę ustawić czas automatycznego zamknięcia	RO	Ţelam namjestiti vrijeme zatvaranja.
EN	I want to set the automatic closing time	NL	Ik wil de automatische sluitingstijd instellen	RU	Хочу установить время автоматического закрытия	HR	Doresc să setez ora de închidere automată
FR	Je veux régler le temps de fermeture automatique	PT	Desejo configurar o tempo de fecho automático	CS	Chci nastavit čas automatického zavírání	AR	أريد ضبط وقت الإغلاق التلقائي
ES	Se desea configurar el tiempo de cierre automático.	EL	Θέλω να ρυθμίσω τον χρόνο αυτόματου κλεισίματος	TR	Otomatik kapanma süresini ayarlamak istiyorum		

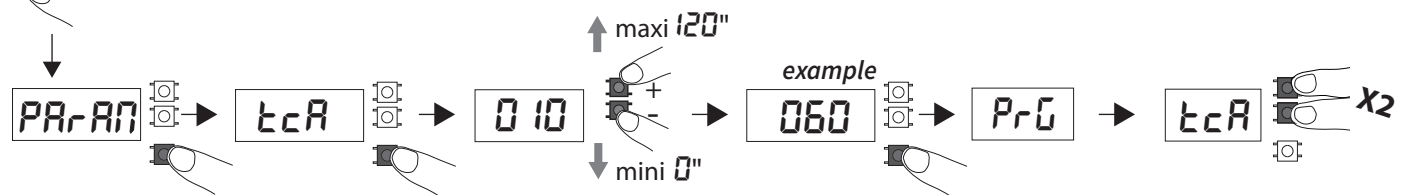
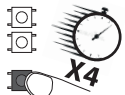

IT	Voglio disattivare la chiusura automatica	DE	Ich möchte das automatische Schließen deaktivieren	PL	Chcę dezaktywować automatyczne zamykanie	RO	Ţelam deactivirati automatisko zatvaranje.
EN	I want to deactivate automatic closing	NL	Ik wil automatischvergrendelen deactiveren	RU	Хочу деактивировать автоматическое закрытие	HR	Doresc să dezactivez închiderea automată
FR	Je veux désactiver la fermeture automatique	PT	Desejo desativar o fecho automático	CS	Chci deaktivovat automatické zavírání	AR	أريد إلغاء تنشيط الإغلاق التلقائي
ES	Se desea desactivar el cierre automático	EL	Θέλω να απενεργοποιήσω το αυτόματο κλείσιμο	TR	Otomatik kapanmayı devre dışı bırakmak istiyorum		

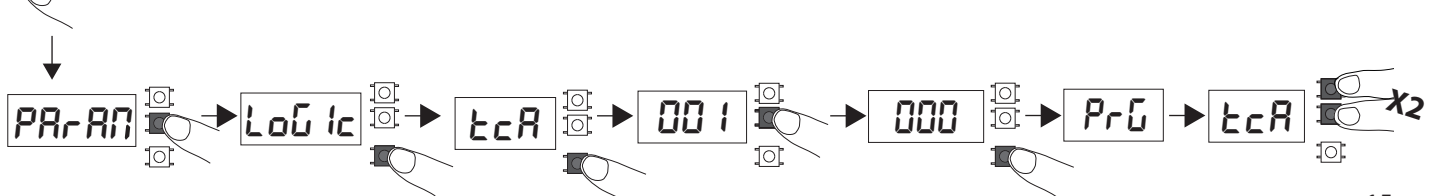

10

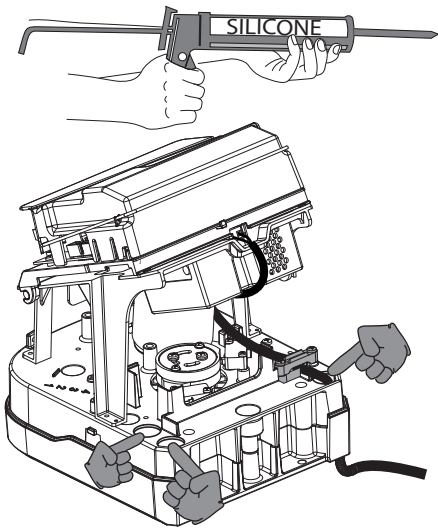

11

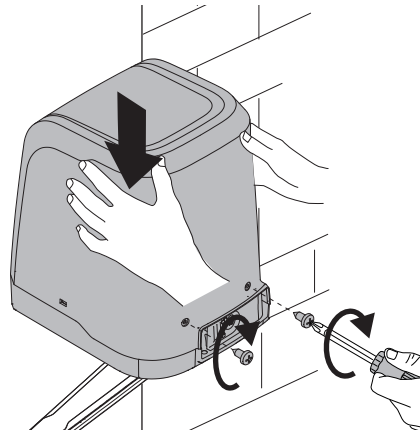

12

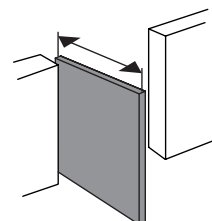
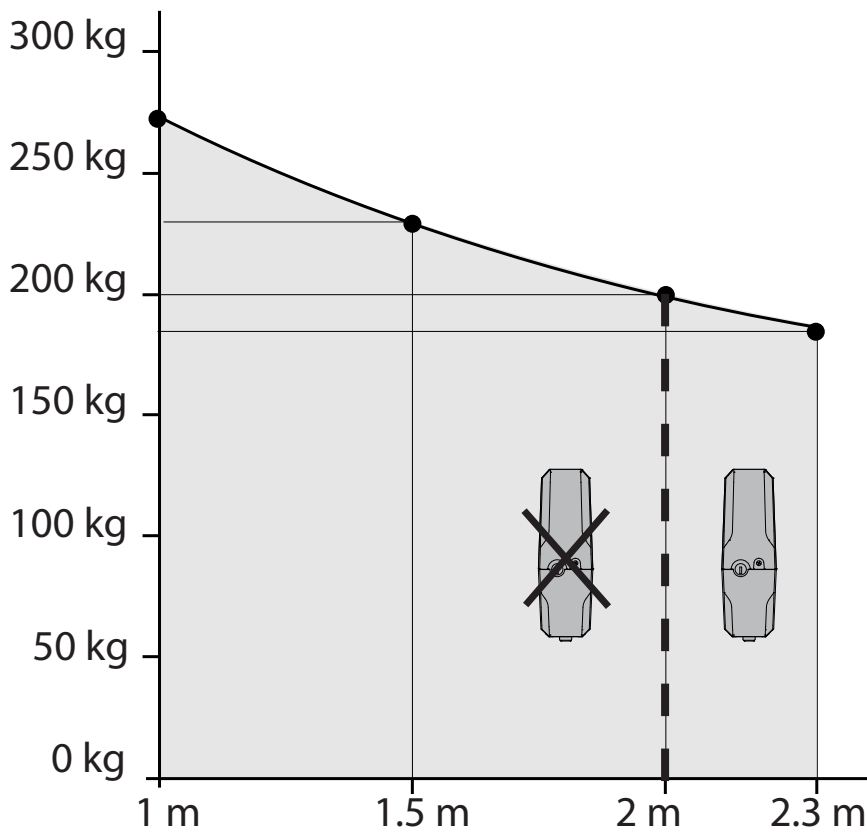
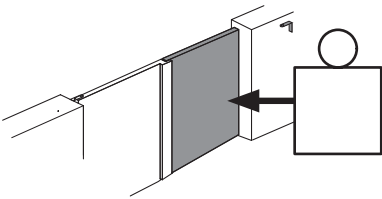

FINAL USER



IT	MANOVRA MANUALE	DE	MANUELLE ÖFFNUNG	PL	OTWIERANIE RĘCZNE	HR	RUČNO OTVARANJE
EN	MANUAL OPENING	NL	HANDMATIGE OPENING	RU	РУЧНОЕ ОТКРЫТИЕ	RO	DESCHIDERE MANUALĂ
FR	OUVERTURE MANUELLE	PT	ABERTURA MANUAL	CS	MANUÁLNÍ OTEVÍRÁNÍ	فتح يدوي	AR
ES	APERTURA MANUAL	EL	XEIPOKINHTO ANOIFMA	TR	MANUEL AÇMA		

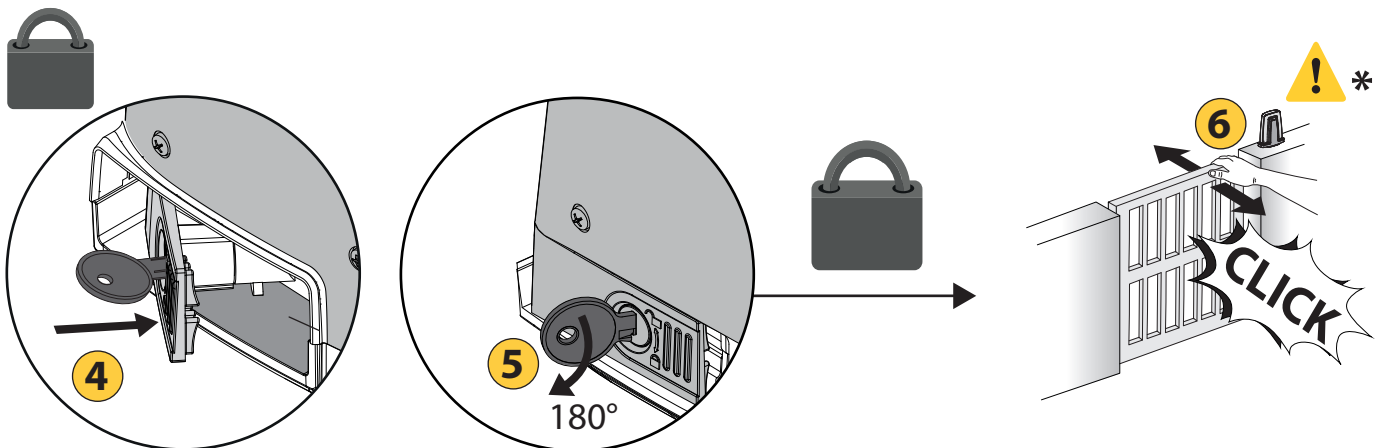
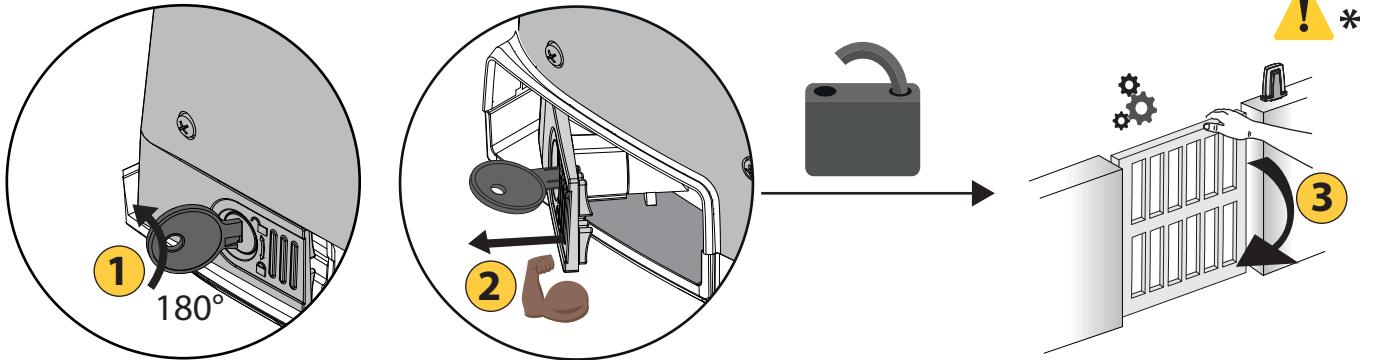

IT	Attenzione! Non spingere VIOLENTEMENTE l'anta del cancello.
EN	Warning! Do not push the gate WITH EXCESSIVE FORCE
FR	Attention! Ne poussez pas VIOLEMMENT le vantail du portail.
ES	¡Atención! No empuje CON VIOLENCIA la hoja de la puerta.
DE	Achtung! Schieben Sie den Torflügel nicht MIT GEWALT an.

NL	Let op! Duw niet MET GEWELD tegen de deur van het hek.
PT	Atenção! Não empurrar COM FORÇA a folha do portão.
EL	Προσοχή! Μην σπρώχνετε ΜΕ ΜΕΓΑΛΗ ΔΥΝΑΜΗ το φύλλο της πύλης.
PL	Uwaga! Nie należy GWAŁTOWNIE popychać skrzydła bramy.
RU	Внимание! Не толкайте СЛИШКОМ СИЛЬНО створку ворот.

CS	Pozor! Na křídlo brány netlačte PŘÍLIŠNOU SILOU.
TR	Dikkat! Kapının kanadını ŞİDDETLİ bir şekilde itmeyin.
HR	Nemojte gurati vrata uz primjenu PREKOMJERNE SILE!
RO	Nu împingeți bariera CU FORȚĂ EXCESIVĂ.
AR	لا تدفع البوابة بقوة زائدة





AZIENDA CON
SISTEMA DI GESTIONE
CERTIFICATO DA DNV GL
= ISO 9001 =
= ISO 14001 =



 www.bft-automation.com BFT Spa Via Lago di Vico, 44 ITALY 36015 Schio (VI) T +39 0445 69 65 11 F +39 0445 69 65 22	SPAIN BFT GROUP ITALIBERICA DE AUTOMATISMOS SL Camí de Can Bassa, 6, 08401 Granollers, Barcelona, Spagna	UNITED KINGDOM BFT AUTOMATION UK LTD Unit C2-C3 The Embankment Business Park, Vale Road Heaton Mersey Stockport Cheshire SK4 3GL United Kingdom	IRELAND BFT AUTOMATION IRELAND Unit D3 City Link Business Park, Old Naas Road, Dublin	U.S.A. BFT AMERICAS INC. 1200 S.W. 35th Avenue Suite B Boynton Beach FL 33426	
	FRANCE AUTOMATISMES BFT FRANCE SAS 50 rue Jean Zay 69800 Saint-Priest, Francia	PORTUGAL BFT PORTUGAL SA Urb. Pedrulha lote 9 - Apartado 8123, 3025-248 Coimbra Portugal	CROATIA BFT ADRIA DOO Obrovac 39, 51218, Dražice, Croazia	AUSTRALIA BFT AUTOMATION AUSTRALIA PTY 29 Bentley St, Wetherill Park NSW 2164, Australia	EMIRATES BFT MIDDLEEAST FZCO FZS2 AA01 - PO BOX 262200, Jebel Ali Free Zone South Zone 2, Dubai - United Arab
	GERMANY BFT ANTRIEBSSYSTEME GMBH Faber-Castell-Straße 29, 90522 Oberasbach, Germania	POLAND BFT POLSKA SP ZOO Marecka 49, 05-220 Zielonka, Polonia	CZECH REPUBLIC BFT CZ SRO Ustecka 533/9, 184 00 Praha 8, Czech	NEW ZEALAND BFT AUTOMATION NEW ZEALAND 224/A Bush Road, Rosedale, Auckland, New Zealand	
			TURKEY BFT OTOMASYON KAPI Şerifali Mahallesi, no, 34775 Ümraniye/Istanbul, Turchia		