

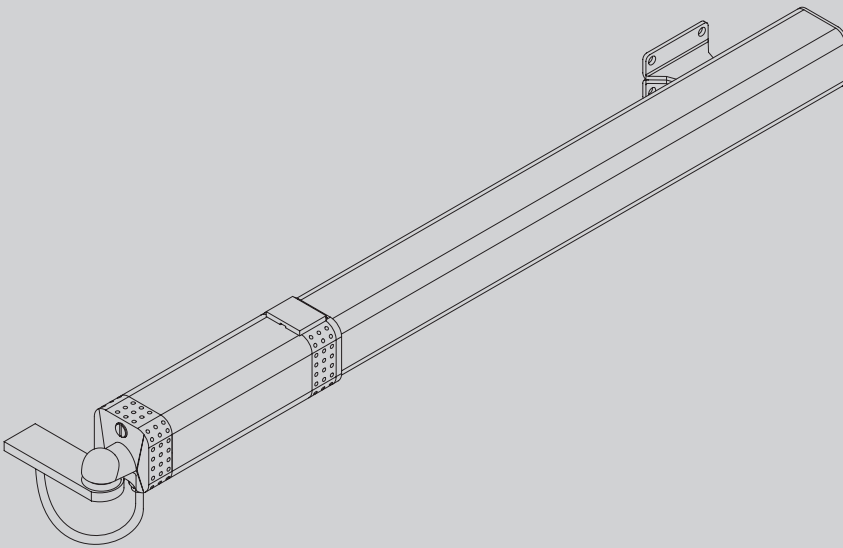

AUTOMAZIONI A PISTONE PER CANCELLI A BATTENTE
 PISTON AUTOMATION FOR SWING GATES
 AUTOMATIONS A PISTON POUR PORTAILS BATTANTS
 KOLBENANTRIEBE FÜR DREHTORE
 AUTOMATIZACIONES A PISTON PARA PORTONES CON BATIENDE
 AUTOMATIZAÇÕES DE PISTÃO PARA PORTÕES DE BATENTE



ISTRUZIONI DI INSTALLAZIONE
 INSTALLATION MANUAL
 INSTRUCTIONS D'INSTALLATION
 MONTAGEANLEITUNG
 INSTRUCCIONES DE INSTALACION
 INSTRUÇÕES DE USO E DE INSTALAÇÃO

ORO - ORO E

BFT



AZIENDA CON SISTEMA DI GESTIONE
 INTEGRATO CERTIFICATO DA DNV
 = UNI EN ISO 9001:2008 =
 UNI EN ISO 14001:2004

INSTALLER WARNINGS

WARNING! Important safety instructions. Carefully read and comply with all the warnings and instructions that come with the product as incorrect installation can cause injury to people and animals and damage to property. The warnings and instructions give important information regarding safety, installation, use and maintenance. Keep hold of instructions so that you can attach them to the technical file and keep them handy for future reference.

GENERAL SAFETY

This product has been designed and built solely for the purpose indicated herein. Uses other than those indicated herein might cause damage to the product and create a hazard.

- The units making up the machine and its installation must meet the requirements of the following European Directives, where applicable: 2004/108/EC, 2006/95/EC, 2006/42/EC, 89/106/EC, 99/05/EC and later amendments. For all countries outside the EEC, it is advisable to comply with the standards mentioned, in addition to any national standards in force, to achieve a good level of safety.
- The Manufacturer of this product (hereinafter referred to as the "Firm") disclaims all responsibility resulting from improper use or any use other than that for which the product has been designed, as indicated herein, as well as for failure to apply Good Practice in the construction of entry systems (doors, gates, etc.) and for deformation that could occur during use.
- Installation must be carried out by qualified personnel (professional installer, according to EN 12635), in compliance with Good Practice and current code.
- Before installing the product, make all structural changes required to produce safety gaps and to provide protection from or isolate all crushing, shearing and dragging hazard areas and danger zones in general in accordance with the provisions of standards EN 12604 and 12453 or any local installation standards. Check that the existing structure meets the necessary strength and stability requirements.
- Before commencing installation, check the product for damage.
- The Firm is not responsible for failure to apply Good Practice in the construction and maintenance of the doors, gates, etc. to be motorized, or for deformation that might occur during use.
- Make sure the stated temperature range is compatible with the site in which the automated system is due to be installed.
- Do not install this product in an explosive atmosphere: the presence of flammable fumes or gas constitutes a serious safety hazard.
- Disconnect the electricity supply before performing any work on the system. Also disconnect buffer batteries, if any are connected.
- Before connecting the power supply, make sure the product's ratings match the mains ratings and that a suitable residual current circuit breaker and overcurrent protection device have been installed upline from the electrical system. Have the automated system's mains power supply fitted with a switch or omnipolar thermal-magnetic circuit breaker with a contact separation that provide full disconnection under overvoltage category III conditions.
- Make sure that upline from the mains power supply there is a residual current circuit breaker that trips at no more than 0.03A as well as any other equipment required by code.
- Make sure the earth system has been installed correctly: earth all the metal parts belonging to the entry system (doors, gates, etc.) and all parts of the system featuring an earth terminal.
- Installation must be carried out using safety devices and controls that meet standards EN 12978 and EN 12453.
- Impact forces can be reduced by using deformable edges.
- In the event impact forces exceed the values laid down by the relevant standards, apply electro-sensitive or pressure-sensitive devices.
- Apply all safety devices (photocells, safety edges, etc.) required to keep the area free of impact, crushing, dragging and shearing hazards. Bear in mind the standards and directives in force, Good Practice criteria, intended use, the installation environment, the operating logic of the system and forces generated by the automated system.
- Apply all signs required by current code to identify hazardous areas (residual risks). All installations must be visibly identified in compliance with the provisions of standard EN 13241-1.
- Once installation is complete, apply a nameplate featuring the door/gate's data.
- This product cannot be installed on leaves incorporating doors (unless the motor can be activated only when the door is closed).
- If the automated system is installed at a height of less than 2.5 m or is accessible, the electrical and mechanical parts must be suitably protected.
- For roller shutter automation only
 - 1) The motor's moving parts must be installed at a height greater than 2.5 m above the floor or other surface from which they may be reached.
 - 2) The gearmotor must be installed in a segregated and suitably protected space so that it cannot be reached without the aid of tools.
- Install any fixed controls in a position where they will not cause a hazard, away from moving parts. More specifically, hold-to-run controls must be positioned within direct sight of the part being controlled and, unless they are key operated, must be installed at a height of at least 1.5 m and in a place where they cannot be reached by the public.
- Apply at least one warning light (flashing light) in a visible position, and also attach a Warning sign to the structure.
- Attach a label near the operating device, in a permanent fashion, with information on how to operate the automated system's manual release.
- Make sure that, during operation, mechanical risks are avoided or relevant protective measures taken and, more specifically, that nothing can be banged, crushed, caught or cut between the part being operated and surrounding parts.
- Once installation is complete, make sure the motor automation settings are correct and that the safety and release systems are working properly.
- Only use original spare parts for any maintenance or repair work. The Firm disclaims all responsibility for the correct operation and safety of the automated system if parts from other manufacturers are used.
- Do not make any modifications to the automated system's components unless explicitly authorized by the Firm.
- Instruct the system's user on what residual risks may be encountered, on the control systems that have been applied and on how to open the system manually in an emergency. Give the user guide to the end user.

- Dispose of packaging materials (plastic, cardboard, polystyrene, etc.) in accordance with the provisions of the laws in force. Keep nylon bags and polystyrene out of reach of children.

WIRING

WARNING! For connection to the mains power supply, use a multicore cable with a cross-sectional area of at least 5x1.5mm² or 4x1.5mm² when dealing with three-phase power supplies or 3x1.5mm² for single-phase supplies (by way of example, type H05RN-F cable can be used with a cross-sectional area of 4x1.5mm²). To connect auxiliary equipment, use wires with a cross-sectional area of at least 0.5 mm².

- Only use pushbuttons with a capacity of 10A-250V or more.
- Wires must be secured with additional fastening near the terminals (for example, using cable clamps) in order to keep live parts well separated from safety extra low voltage parts.
- During installation, the power cable must be stripped to allow the earth wire to be connected to the relevant terminal, while leaving the live wires as short as possible. The earth wire must be the last to be pulled taut in the event the cable's fastening device comes loose.

WARNING! safety extra low voltage wires must be kept physically separate from low voltage wires.

Only qualified personnel (professional installer) should be allowed to access live parts.

CHECKING THE AUTOMATED SYSTEM AND MAINTENANCE

Before the automated system is finally put into operation, and during maintenance work, perform the following checks meticulously:

- Make sure all components are fastened securely.
- Check starting and stopping operations in the case of manual control.
- Check the logic for normal or personalized operation.
- For sliding gates only: check that the rack and pinion mesh correctly with 2 mm of play along the full length of the rack; keep the track the gate slides on clean and free of debris at all times.
- For sliding gates and doors only: make sure the gate's running track is straight and horizontal and that the wheels are strong enough to take the weight of the gate.
- For cantilever sliding gates only: make sure there is no dipping or swinging during operation.
- For swing gates only: make sure the leaves' axis of rotation is perfectly vertical.
- For barriers only: before opening the door, the spring must be decompressed (vertical boom).
- Check that all safety devices (photocells, safety edges, etc.) are working properly and that the anti-crush safety device is set correctly, making sure that the force of impact measured at the points provided for by standard EN 12445 is lower than the value laid down by standard EN 12453.
- Impact forces can be reduced by using deformable edges.
- Make sure that the emergency operation works, where this feature is provided.
- Check opening and closing operations with the control devices applied.
- Check that electrical connections and cabling are intact, making extra sure that insulating sheaths and cable glands are undamaged.
- While performing maintenance, clean the photocells' optics.
- When the automated system is out of service for any length of time, activate the emergency release (see "EMERGENCY OPERATION" section) so that the operated part is made idle, thus allowing the gate to be opened and closed manually.
- If the power cord is damaged, it must be replaced by the manufacturer or their technical assistance department or other such qualified person to avoid any risk.
- If "D" type devices are installed (as defined by EN12453), connect in unverified mode, foresee mandatory maintenance at least every six months
- The maintenance described above must be repeated at least once yearly or at shorter intervals where site or installation conditions make this necessary.

WARNING!

Remember that the drive is designed to make the gate/door easier to use and will not solve problems as a result of defective or poorly performed installation or lack of maintenance



SCRAPPING

Materials must be disposed of in accordance with the regulations in force. Do not throw away your discarded equipment or used batteries with household waste. You are responsible for taking all your waste electrical and electronic equipment to a suitable recycling centre.

DISMANTLING

If the automated system is being dismantled in order to be reassembled at another site, you are required to:

- Cut off the power and disconnect the whole electrical system.
- Remove the actuator from the base it is mounted on.
- Remove all the installation's components.
- See to the replacement of any components that cannot be removed or happen to be damaged.

Anything that is not explicitly provided for in the installation manual is not allowed. The operator's proper operation can only be guaranteed if the information given is complied with. The Firm shall not be answerable for damage caused by failure to comply with the instructions featured herein.

While we will not alter the product's essential features, the Firm reserves the right, at any time, to make those changes deemed opportune to improve the product from a technical, design or commercial point of view, and will not be required to update this publication accordingly.

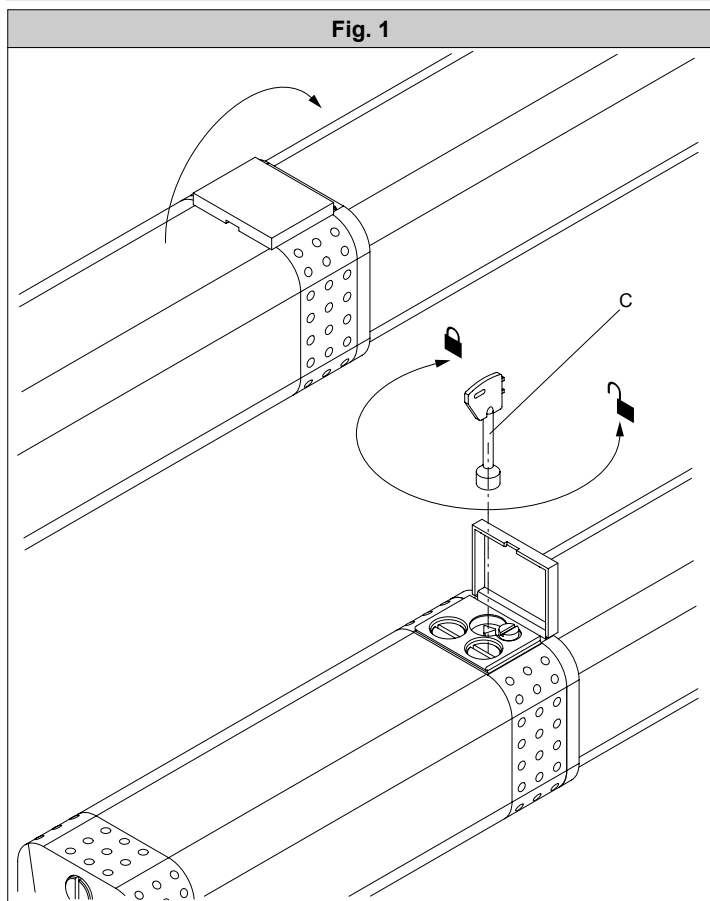

(I)

1) SICUREZZA

Non tentare di aprire manualmente il cancello se:

- Nel modello **ORO/E** non è stata sbloccata l'elettroserratura con l'apposita chiave.
- Nel modello **ORO** non è stato azionato lo sblocco con l'apposita chiave (Fig.1).

2) MANOVRA DI EMERGENZA

2.1) Mod. ORO

Nei casi di emergenza, per esempio in mancanza di energia elettrica, per sbloccare il cancello infilare la chiave C per la regolazione della valvola by-pass nel perno triangolare (Fig.1) e ruotarla in senso antiorario. Il cancello è così apribile manualmente. Per ripristinare il funzionamento elettrico dell'attuatore, girare la chiave in senso orario fino al completo bloccaggio del perno.

2.2) Mod. ORO/E

Essendo questi modelli reversibili per la manovra manuale del cancello è sufficiente aprire l'elettroserratura con la relativa chiave. Per rendere più agevole la manovra manuale, si può attivare lo sblocco tramite il perno triangolare, al quale si ha l'accesso con l'apposita chiave

(GB)

1) SAFETY

Do not attempt to open the gate manually if:

- In mod. **ORO/E** the electric lock has not been released by means of the appropriate key.
- In mod. **ORO** the release has not been activated by means of the appropriate key (fig.1).

2) EMERGENCY MANOEUVRE

2.1) Mod. ORO

In case of emergency, for example when the electrical power is disconnected, to release the gate, insert the same key C used for the adjustment of the by-pass valve inside the triangular pin (Fig.1) and rotate it counter-clockwise. The gate can now be opened manually. To reset the electric operation of the actuator, turn the key in clockwise direction until pin is blocked.

2.2) Mod. ORO/E

Since these models are reversible, for the manual operation of the gate it is sufficient that the lock be opened with the appropriate key. To make the manual manoeuvre easier, the lock can be released by means of a triangular pin which can be reached using the appropriate key.

(F)

1) SÉCURITÉ

Ne pas tenter d'ouvrir manuellement le portail si :

- dans le modèle **ORO/E** l'électroserrure n'a pas été débloquée avec la clé spéciale.
- dans le modèle **ORO** le déblocage n'a pas été activé avec la clé spéciale (fig.1).

2) MANŒUVRE D'URGENCE

2.1) Mod. ORO

Dans les cas d'urgence, par exemple en cas de coupure d'électricité, pour débloquer le portail il faut introduire la clé C, qui sert aussi pour le réglage de la soupape de dérivation, dans le pivot triangulaire (Fig.1) et la tourner dans le sens contraire à celui des aiguilles d'une montre. Le portail peut de cette façon être ouvert manuellement. Pour reprendre le fonctionnement électrique initial de l'actionneur, tourner la clé dans le sens des aiguilles d'une montre jusqu'au blocage complet du pivot.

2.2) Mod. ORO/E

Ces modèles sont réversibles, donc pour la manoeuvre manuelle du portail il suffit d'ouvrir l'électroserrure avec la clé relative. Pour faciliter la manoeuvre manuelle, on peut activer le déblocage manuel au moyen du pivot triangulaire accessible avec la clé spéciale.

(D)

1) SICHERHEIT

Versuchen Sie nicht, das Tor von Hand zu öffnen, wenn:

- Das Elektroschloss beim Modell **ORO/E** nicht vorher mit dem passenden Schlüssel entriegelt wurde.
- Wenn die Verriegelungsvorrichtung beim Modell **ORO** nicht vorher mit dem passenden Schlüssel entsperrt wurde (Abb.1).

2) HANDHABUNG DES TORES IM NOTFALL

2.1) Mod. ORO

Im Notfall, etwa bei Stromausfall, kann das Tor folgendermaßen entriegelt werden: Den Schlüssel C für die Einstellung des Bypass-Ventils in den Dreieckzapfen stecken (Abb.1) und gegen den Uhrzeigersinn drehen. Das Tor lässt sich danach von Hand öffnen. Um den elektrischen Betrieb des Antriebes wieder aufzunehmen, den Schlüssel solange im Uhrzeigersinn drehen, bis der Zapfen vollständig blockiert ist.

2.2) Mod. ORO/E

Da diese Modelle für die Handbedienung reversibel sind, reicht es aus, das Elektroschloss mit dem zugehörigen Schlüssel zu öffnen. Um die Handbedienung bequemer zu gestalten, kann die Entsperrungsvorrichtung durch Einstecken des passenden Schlüssels in den Dreieckzapfen betätigt werden.

ADVERTENCIAS PARA EL USUARIO (E)

1) SEGURIDAD

No intentar abrir manualmente la cancela si antes:

- en el modelo **ORO/E**, no se ha desbloqueado la electrocerradura con la llave correspondiente.
- en el modelo **ORO**, no se ha accionado el dispositivo de desbloqueo con la llave correspondiente (fig.1).

2) MANIOBRA DE EMERGENCIA

2.1) Mod. ORO

En casos de emergencia, por ejemplo cuando falta el suministro de corriente, para desbloquear la cancela, hay que introducir la llave C, utilizada para la regulación de la válvula by-pass, en el perno triangular (fig.1) y girarla en sentido contrario a las agujas del reloj. La cancela, de esta manera, se puede abrir manual-

mente. Para restablecer el funcionamiento eléctrico del servomotor, habrá que girar la llave en el sentido de las agujas del reloj hasta que el perno quede completamente bloqueado.

2.2) Mod. ORO/E

Al ser estos modelos reversibles, para mover manualmente la cancela es

suficiente con abrir la electrocerradura con la llave correspondiente.

Para hacer más fácil la maniobra manual, se puede activar el dispositivo

de desbloqueo mediante el perno triangular, al cual se puede acceder con la llave correspondiente.

ADVERTÊNCIAS PARA O UTILIZADOR (P)

2) SEGURANÇA

Não tente de abrir manualmente o portão se:

- No modelo **ORO/E** não foi desbloqueada a fechadura eléctrica com a chave específica.
- No modelo **ORO** não foi accionado o desbloqueio com a chave específica (Fig.1).

2) MANOBRA DE EMERGÊNCIA

2.1) Mod. ORO

Nos casos de emergência, por exemplo na falta de energia eléctrica, para desbloquear o portão introduza a chave C, para a regulação da válvula de desvio, no perno triangular (Fig.1) e gire-a no sentido anti-horário. Desta maneira o portão pode ser aberto manualmente. Para restabelecer o funcionamento eléctrico do accionador, gire a chave no sentido horário até ao bloqueio completo do perno.

2.2) Mod. ORO/E

Uma vez que estes modelos são reversíveis, para a manobra manual do portão é suficiente abrir a fechadura eléctrica com a respectiva chave. Para facilitar a manobra manual, pode-se activar o desbloqueio através do perno triangular, ao qual se tem acesso com a chave específica.

Fig. 1

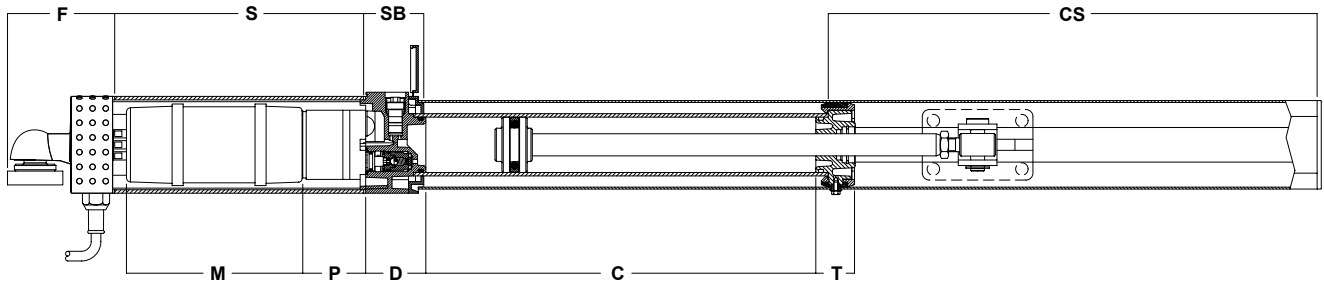
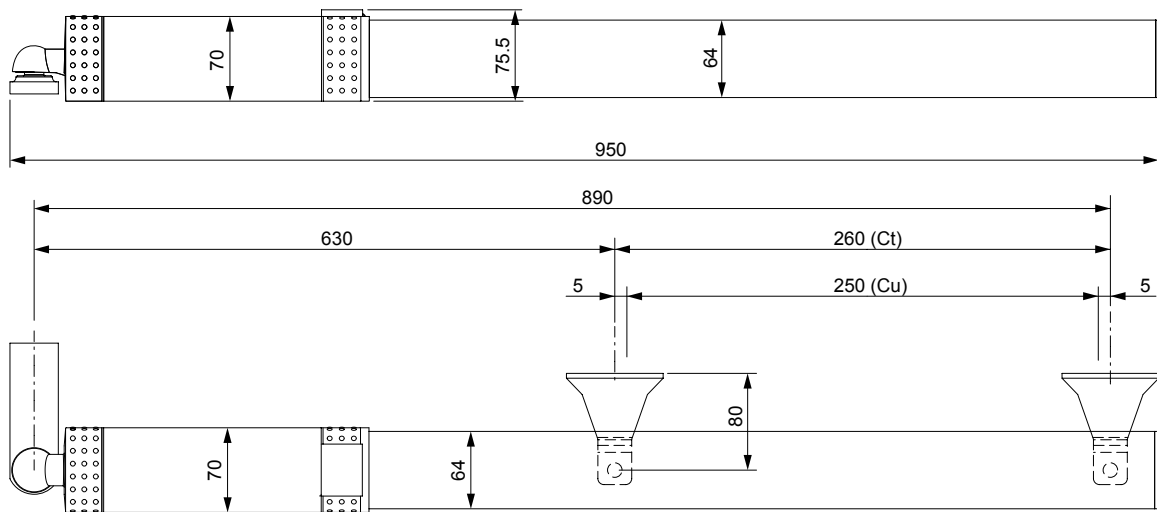

Fig. 2



Ct = Corsa totale
Total stroke
Course totale
Totalhub
Carrera total

Cu = Corsa utile
Working stroke
Course utile
Nutzhub
Carrera útil

Fig. 3

a (mm) \ b (mm)	80	90	100	110	120	130	140	150	160
80					112	104	99	94	91
90					105	99	94	91	88
100					100	94	91		
110					95	89	87		
120			103	95	90				
130		106	95	90	86				
140		96	89						
150	97	89	84						
160	88	83	80						α°

Fig. 4

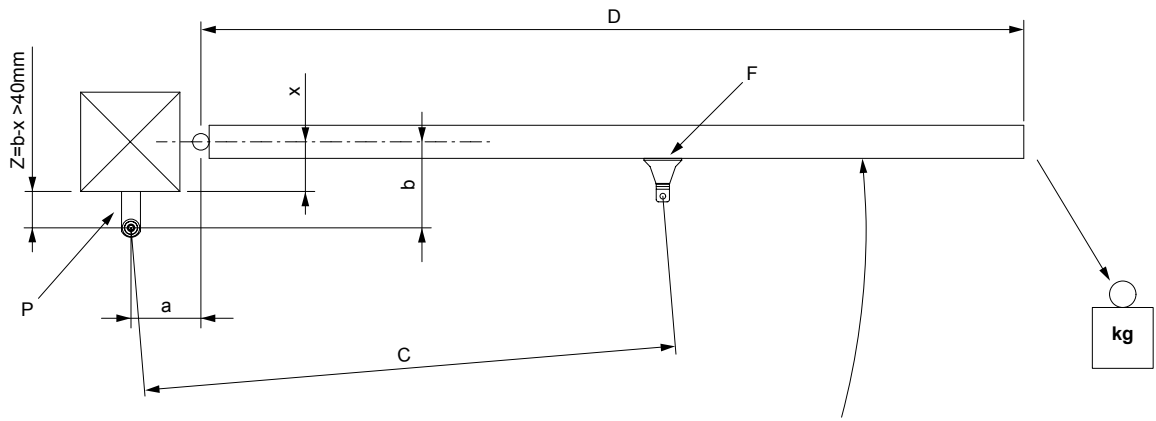

Fig. 5

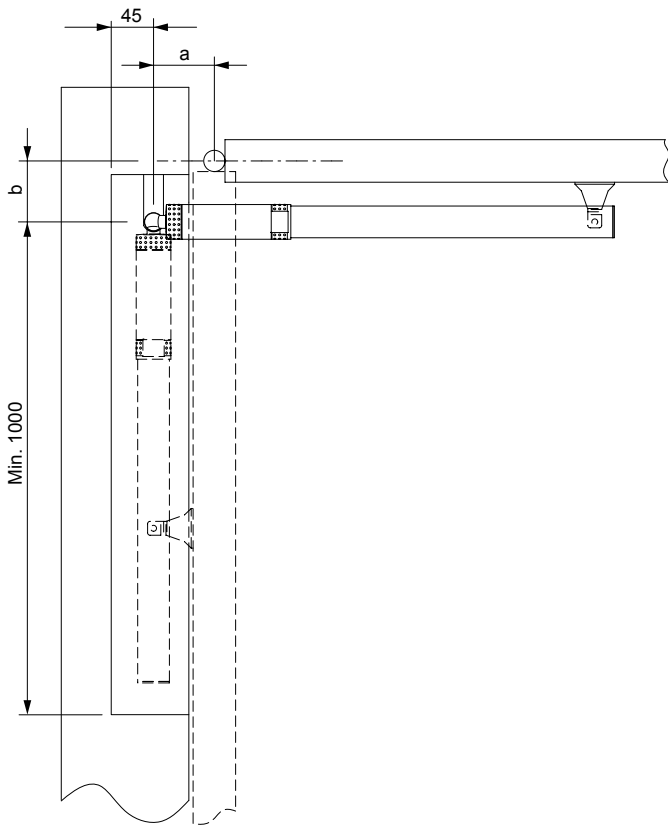

Fig. 6

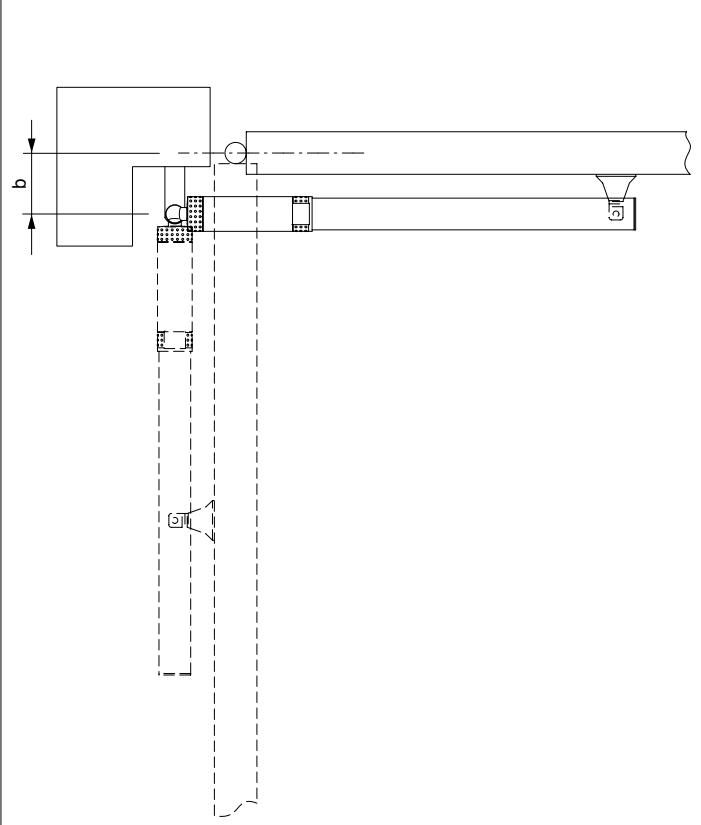

Fig. 7

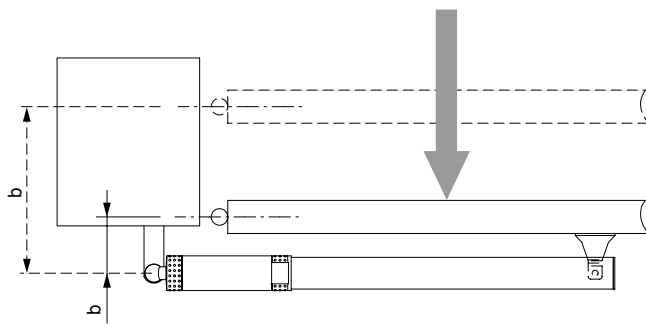
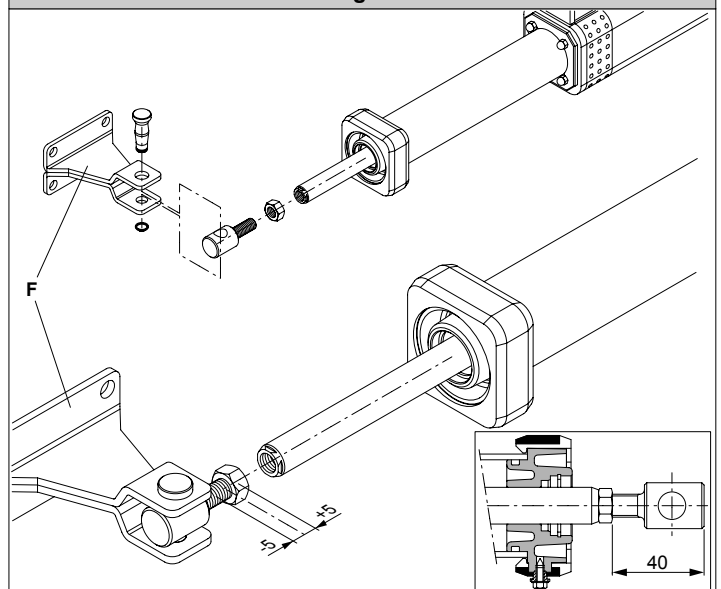

Fig. 8



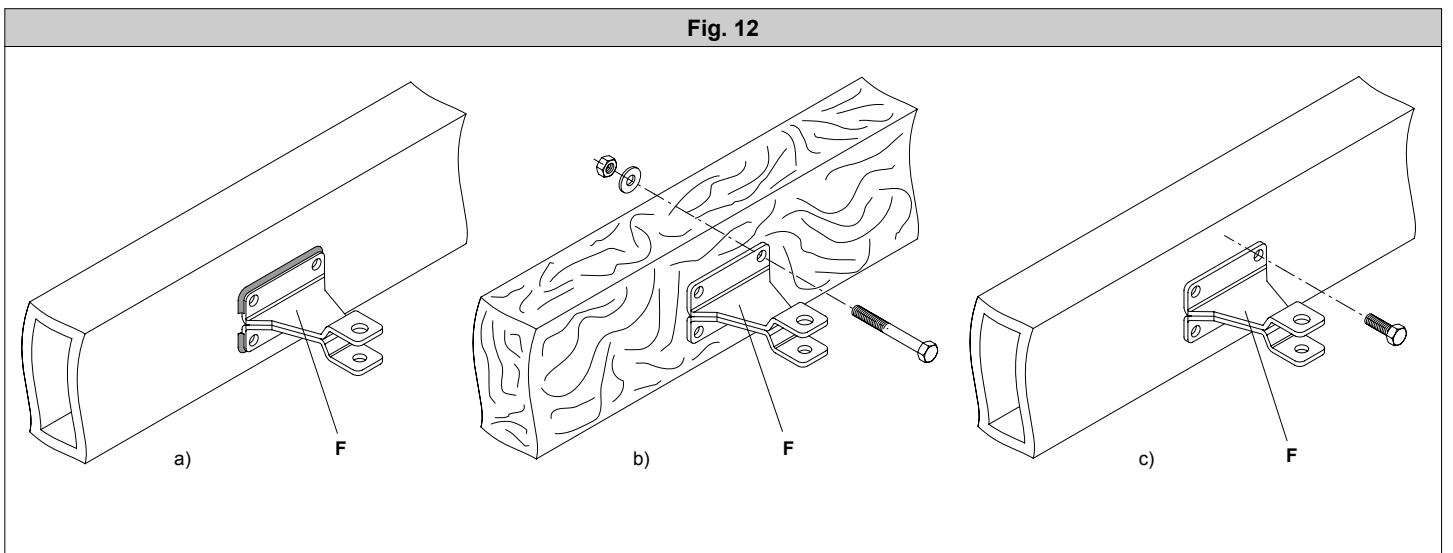
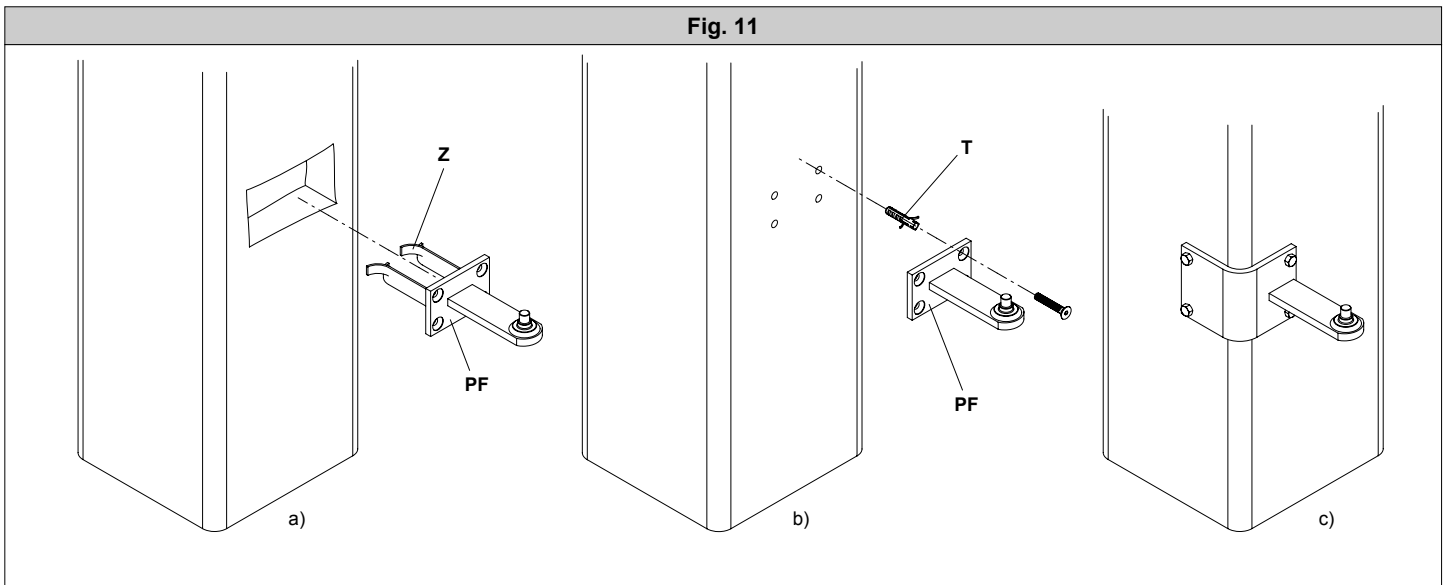
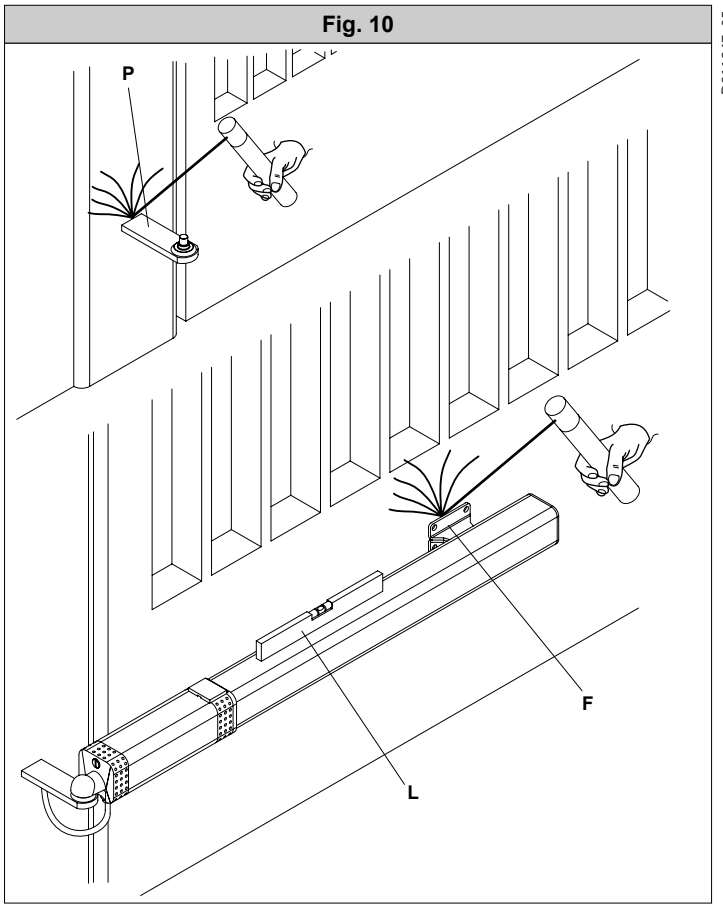
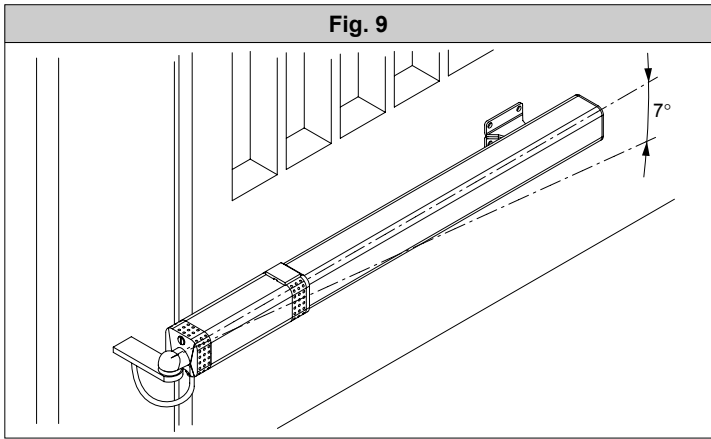
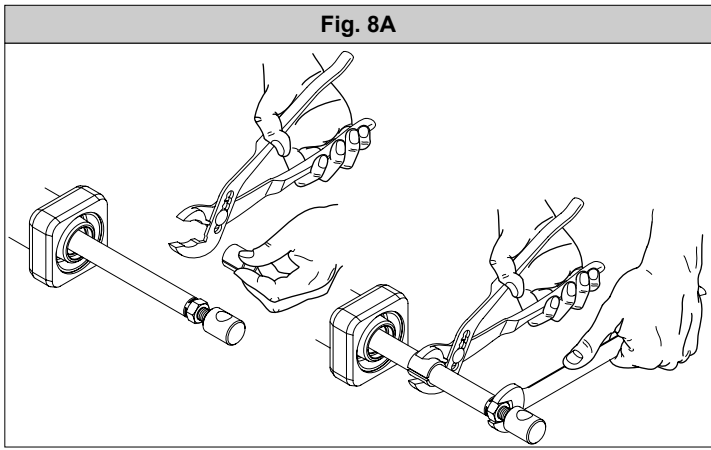

Fig. 13

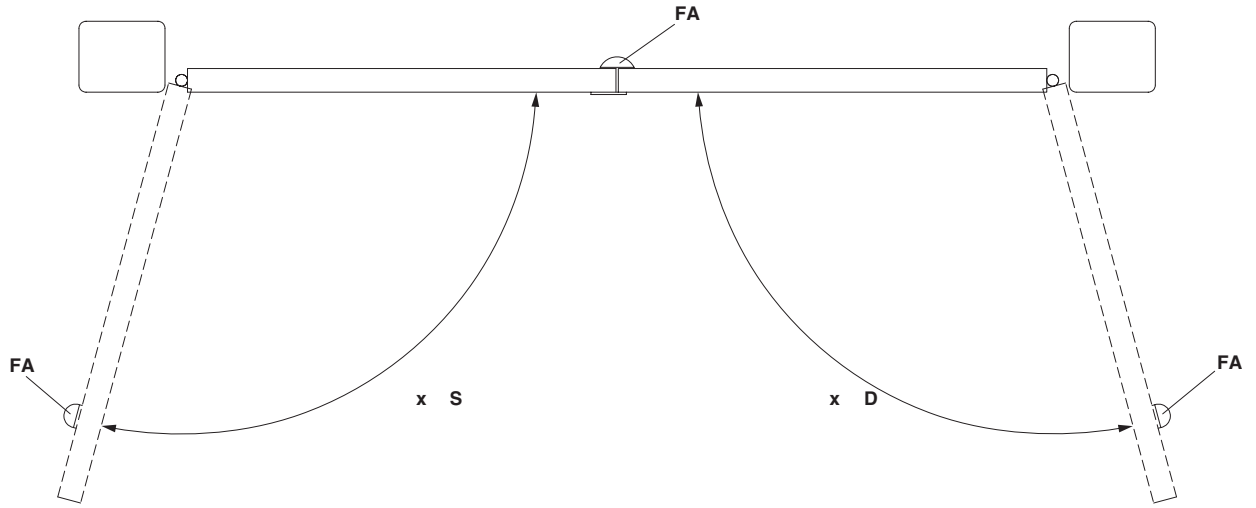

Fig. 14

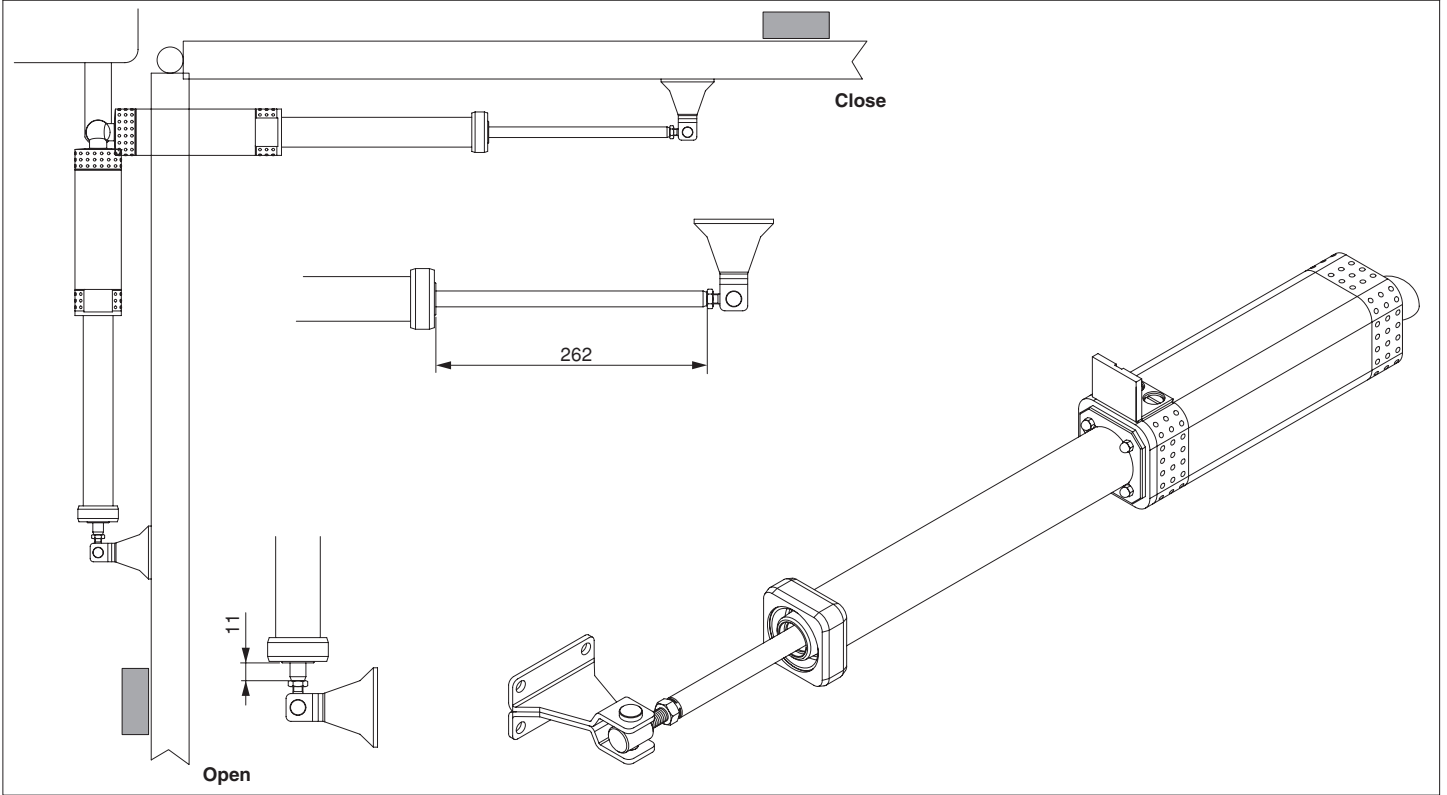

Fig. 15

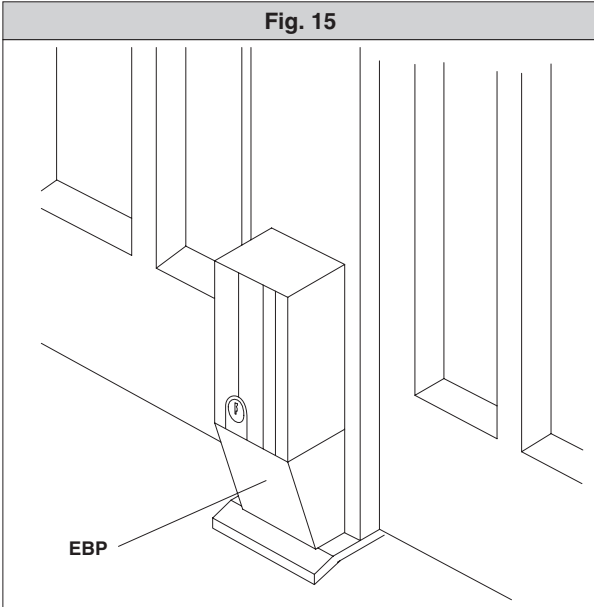

Fig. 16

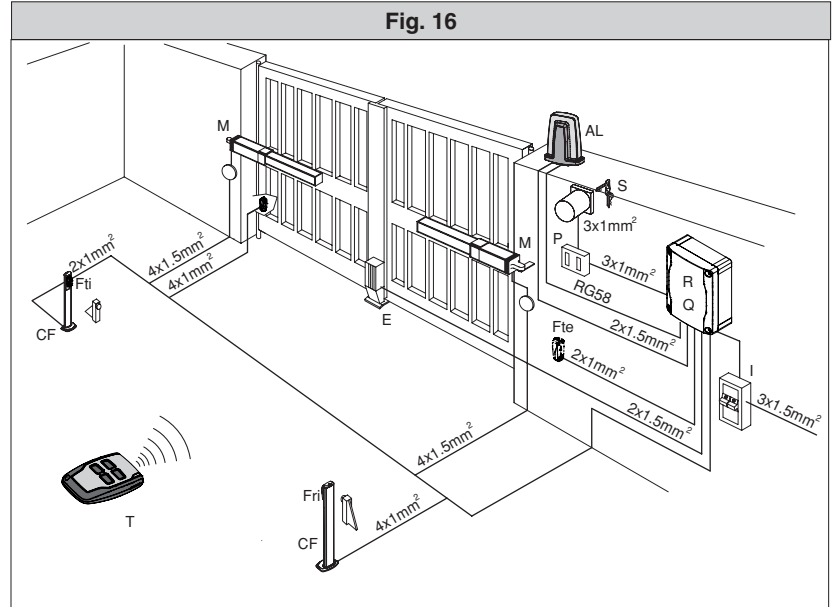

Fig. 17

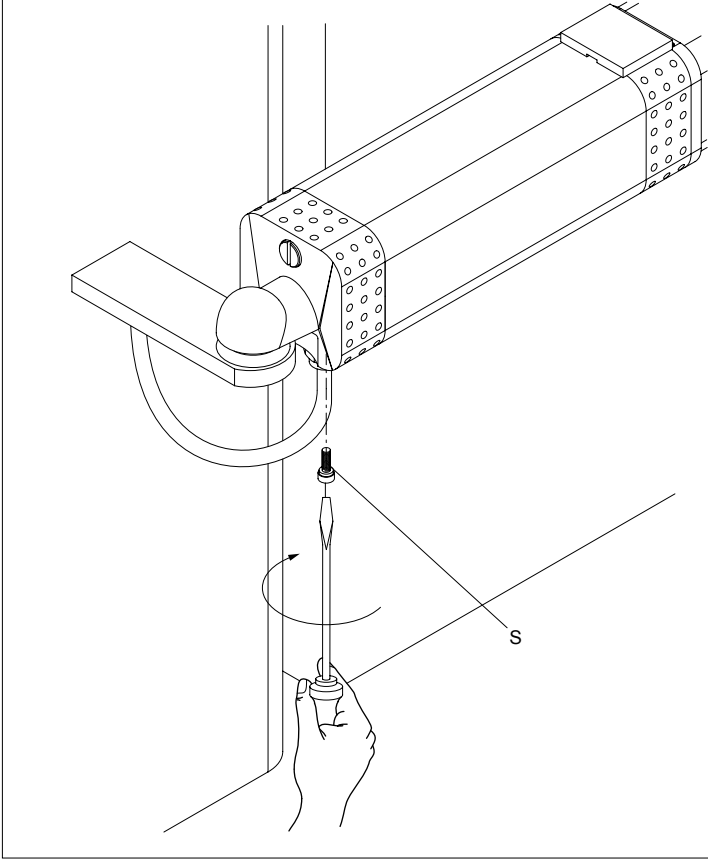

Fig. 18

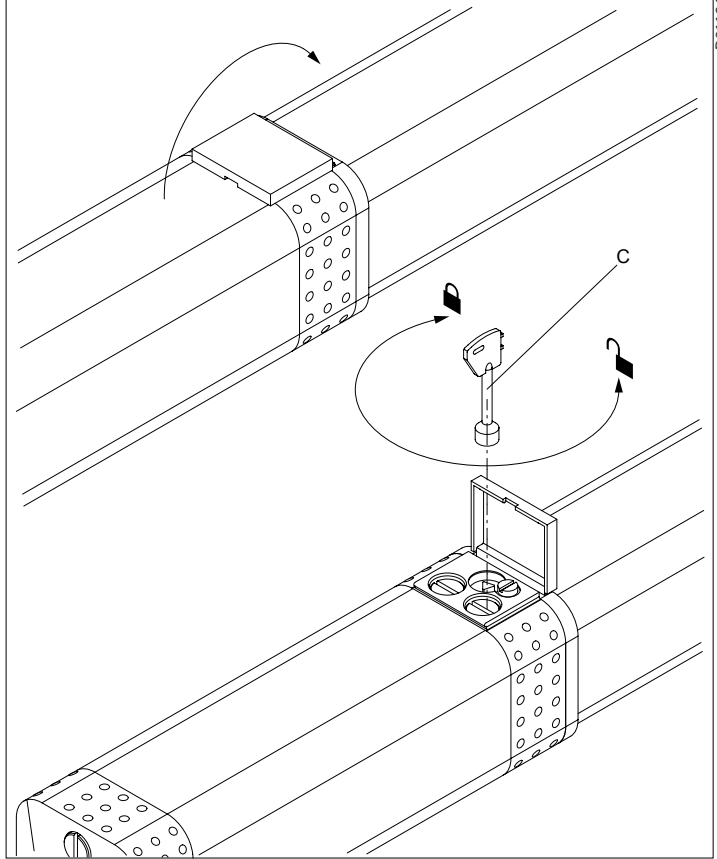

Fig. 19

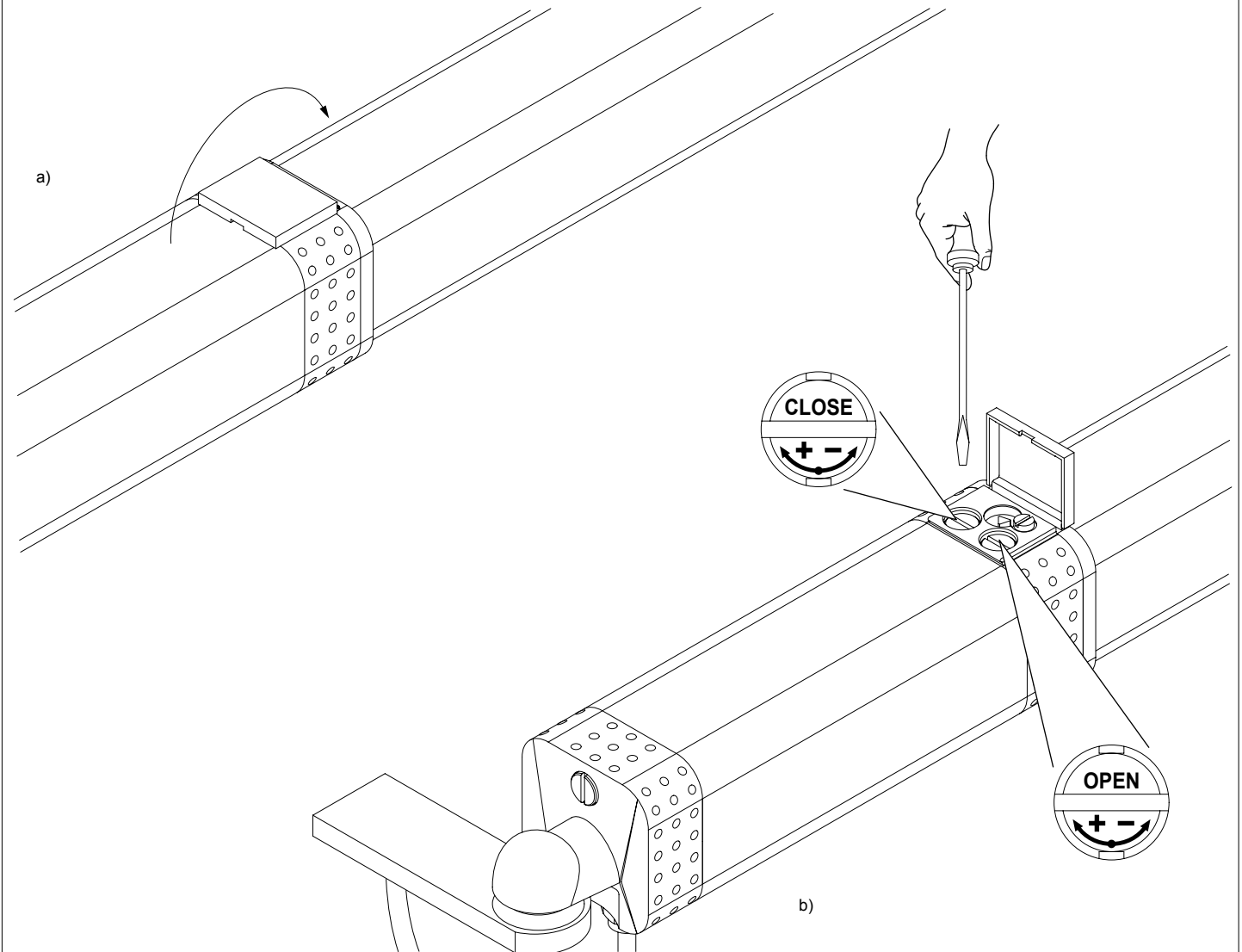

Fig. 20

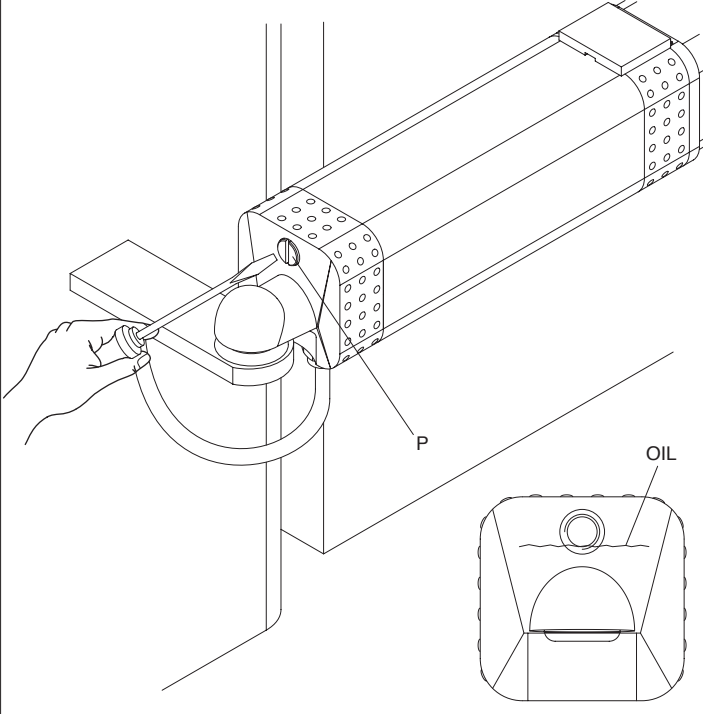

Fig. 22

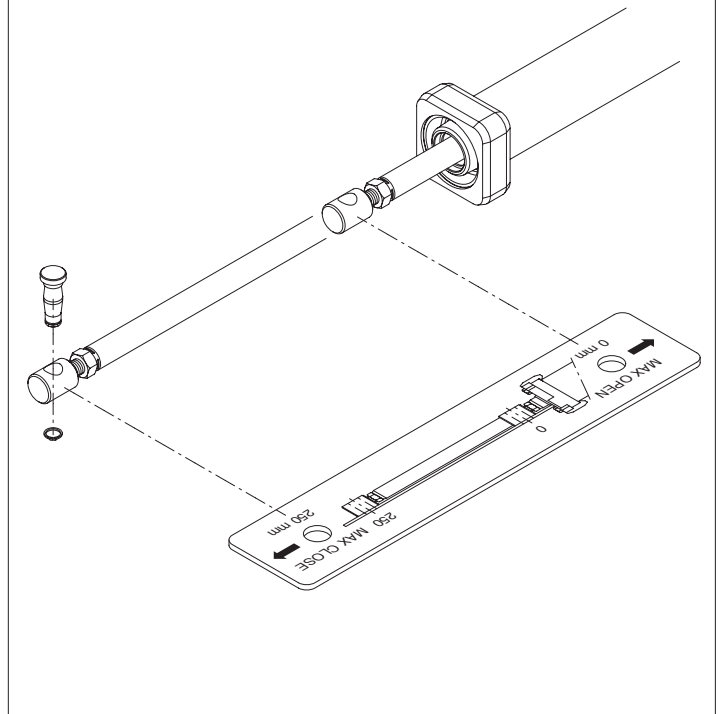
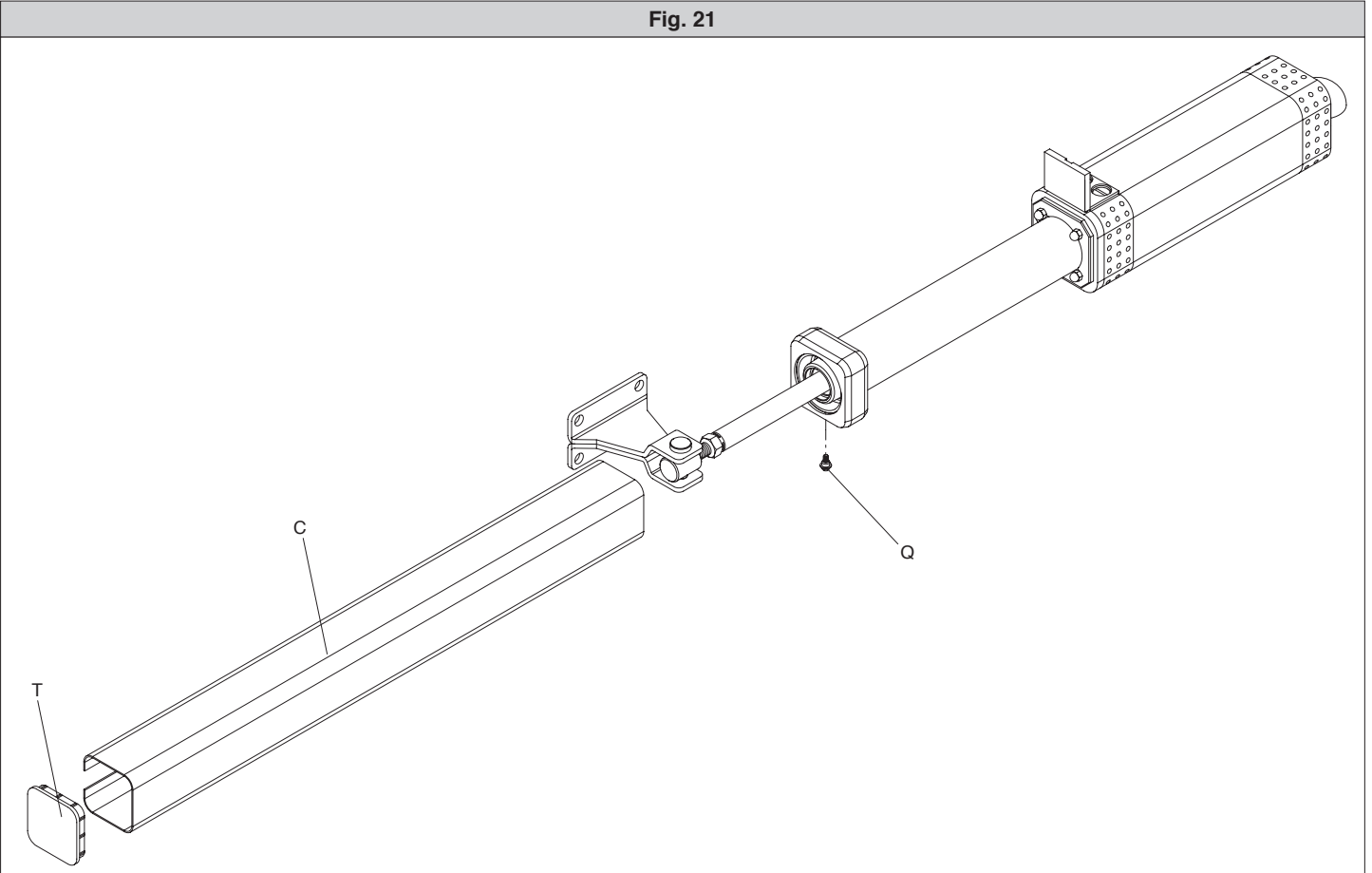

Fig. 21



2) GENERAL OUTLINE

A compact sturdy hydraulic piston, available in various versions according to the user's requirements and type of operation. They are models available with a hydraulic lock on closing or without a hydraulic lock in which an electric lock is required. To make the manual manoeuvre easier, the lock can be released by means of a triangular pin which can be reached using the appropriate key. The pushing force is adjusted with extreme precision by means of two bypass valves which provide antisquash safety. The end-of-stroke operation is electronically set in the control panel by means of a timer. All models are available with slow-down function during the closing phase.

3) MAIN AUTOMATION PARTS (fig.1)

- M) 2-pole single-phase motor, protected by thermal circuit-breaker.
- P) Hydraulic cam pump.
- D) Distributor with adjustment valves.
- C) Cylinder with piston.
- CS) Rod cover.
- S) Reservoir.
- SB) Release.
- T) Head.
- F) Base with articulated joint.

Components supplied: Attachments for pillars and gate - personalised release key - drive capacitor - instruction manual.

4) TECHNICAL SPECIFICATIONS

	Mod. ORO	Mod. ORO/E
Power supply	: 220-230V 50/60Hz	
	(special voltage on request)	
Motor	: 2800min ⁻¹	
Absorbed power	: 240W	
Capacitor	: 6.3µF	
Max. pressure	: 2MPa (20bar)	
Pump capacity	: 0.9l/min	: 0.6l/min
Pushing force	: 1500N	
Towing force	: 1250N	
Opening time (working stroke)	: 20s	: 27s
Closing time (working stroke)	: 20s	: 27s
Type of lock	: Hydraulic lock	: Electric lock
	on closing	on closing/opening
Max leaf length	: 1.8m	: 2.5m
Max. leaf weight	: 1800N (~180kg)	: 2000N (~200kg)
Working stroke	: 250mm	
Manoeuvres in 24 hours	: 60	
Impact reaction	: Hydraulic clutch	
Manual manoeuvre	: Release key	
Thermal protection	: 120°C	
Environmental conditions	: -10°C to +60°C	
Degree of protection	: IP55	
Controller weight	: 53N (~5,3kg)	
Dimensions	: see fig. 2	
Oil	: Idrolux Oil if not differently indicated on the actuator (0.75 litres)	
Sound pressure:	: <70dB(A)	

5) ACTUATOR INSTALLATION

5.1) Preliminary checks

Check that:

- The gate structure is sufficiently sturdy.
- Also make sure that the actuator pushes against the leaf reinforced section.
- The leaves move manually and without effort all along their stroke.
- The door stop plates are fitted at the end of both closing and opening strokes.
- If the gate has not been recently installed, check the wear condition of all components.
- Repair or replace faulty or worn parts.

The automation reliability and safety are directly influenced by the state of the gate structure.

5.2) Installation dimensions

The installation dimensions can be worked out from the table concerning the respective model (fig.3) and with reference to the diagram in fig.4. The diagram in fig.4 uses the following conventional references:

- P Rear bracket fixed to pillar.
- F Leaf fixing front fork.
- a-b Dimensions used to determine the fixing point for bracket "P".
- C Value of fixing distance between centres.
- D Leaf length.
- x Distance from the leaf axis to the pillar edge.
- Z Value always greater than 40mm (b - x).
- kg Max leaf weight (see **Technical specifications**).
- α° Leaf opening angle.

5.3) How to interpret the installation measurements (fig.3)

The table represents the recommended dimensions A and B based on the length of the gate and of the decided opening angle in degrees α°. The smaller are the values of A and B, the less is the opening-closing time of the gate. The larger are the A and B values, the greater is the force developed by the piston; (for small but heavy gates or others with considerable friction it is recommended that the values of A and B be increased). If the values A and B are too unlike, this can cause a speed variation during the opening and closing, with the possibility of oscillations and the possibility of gate jamming.

WARNING! All versions are provided with a ball joint which allows the rod to be lengthened or shortened by approximately 5mm, but only if it was fixed using the dimensions shown in fig.8 before installation after installation, this adjustment allows the rod stroke to be corrected.

Fig.9 illustrates the oscillation that the controllers may show with respect to their horizontal axis.

During installation, carefully follow all the phases described below, taking care to protect the actuator's chromium-plated rod at all times, in order to prevent it from being damaged by impact or any welding slag.

- 1) Identify "a - b - α°" in the table in fig. 3.
- 2) Fix bracket "P" (fig.10) to the pillar.
- 3) Fit the piston in bracket "P".
- 4) Make sure that the rod eye is adjusted see fig 8.
- 5) Pull the rod out completely after activating the emergency release (fig.18)
- 6) Push the rod back in manually until you position the eye hole with the hole of the template (fig.22).
- 7) Fit fork "F" (fig.8) to the rod.
- 8) Fully close the gate leaf against the centre stop plate.
- 9) Keeping the piston level, mark the position for attaching fork (fig. 10 ref. "F") to the leaf.
- 10) Remove fork "F" from the rod and move the piston sideways.
- 11) Fix fork (fig.10 ref. "F") to the leaf by means of screws or welding.
- 12) Reconnect the rod to fork "F" remove bleed screw "S" (Fig.17) and supply the actuator with power.
- 13) Make some full cycles.
- 14) In the case when you have to adjust the opening angle, do so by adjusting the ball joint see fig.8.
- 15) After adjustment proceed as follows in order to secure piston into mounting bracket: clean piston cover and secure with fastener, insert mounting pin and tighten lock nut with open end wrench as shown in fig.8A.

5.4) Suggestions for particular installations

Fig.5 A recess must be made to house the controller when the leaf is completely open; the recess measurements are shown in fig.5.

Fig.7 When the "b" dimension is greater than the values shown in the installation tables, it is necessary to move the leaf hinge-pivot or make a recess in the pillar, as in fig.6.

5.5) Anchoring of attachments to the pillar

Weld or fix the bracket base supplied to the pillar, check the "a" and "b" measurements and then weld plate "P" to the said base. (fig. 10).

- If the pillar is made of masonry, plate "P" must be welded to the metal base "PF" and deeply anchored by means of suitable hooks "Z" which are to be welded on the back of the said base (fig. 11a).
- If the pillar is made of stone, plate "P" is welded to the metal base "PF" and can be fixed by means of four metal screw anchors "T" (fig. 11b); if the gate is large, it is advisable to weld plate "P" to an angle-shaped base (fig. 11c).

5.6) Anchoring of attachments to the leaf

Weld or fix fork "F" to the leaf at distance between centres "C" shown in fig.4, making sure that the actuator is perfectly level (level "L", fig. 10) with respect to the gate movement plane.

- If the gate is made of metal, the fork can be welded (fig. 12a) or fixed using appropriate screws (fig. 12c).
- If the gate is made of wood, the fork can be fixed using appropriate screws (fig. 12b).

6) GROUND LEAF STOP PLATES

For the actuator to operate correctly, stop plates "FA" must be used during both opening and closing manoeuvres, as shown in fig. 13.

The leaf stop plates must prevent the actuator rod from going to the end-of-stroke position. Fig.14 specifies the dimensions needed to check the correct actuator installation both for pushing and towing. The plates must be positioned in such a way as to maintain a rod stroke margin of approximately 5mm; this is to avoid possible operation anomalies (such as a lock-up).

7) ELECTRIC LOCK FITTING

This is needed on mod. **ORO/E** only since these are not supplied with a hydraulic lock on closing.

The **EBP** model electric lock (fig.15) consists of a continuous service electromagnet being anchored to the ground.

This device remains energized throughout the actuator operation time, and allows the catch to stay lifted when it reaches the closing position, without opposing any resistance; the catch will drop into position when the gate has completed the closing cycle.

The electric lock can also be used to keep the block of the gate in case of actuator malfunction or current failure.

8) ELECTRICAL INSTALLATION SET-UP

Lay out the electrical installation (fig. 16) with reference to the CEI 64-8 and IEC 364 provisions, complying with the HD 384 and other national standards in force for electrical installation. The mains power supply connections must be kept totally separate from the service connections (photocells, electric edges, control devices etc.).

WARNING! For connection to the mains power supply, use a multicore cable with a cross-sectional area of at least 3x1.5mm² of the kind provided for by the regulations in force. To connect the motors, use a cable with a cross-sectional area of at least 1.5mm² of the kind provided for by the regulations in force. The cable must be type H05RN-F at least.

Connect the control and safety devices in compliance with the previously mentioned electrical installation standards.

Fig.16 shows the number of connections and the cross section for power supply cables having a length of approximately 100 metres; in case of longer cables, calculate the cross section for the true automation load.

When the auxiliary connections exceed 50-metre lengths or go through critical disturbance areas, it is recommended to decouple the control and safety devices by means of suitable relays.

8.1) The main automation components are (fig.16):

I Type-approved omnipolar circuit breaker with at least 3mm contact opening, provided with protection against overloads and short circuits, suitable for cutting out automation from the mains. If not already installed, place a type-approved differential switch with a 0.03A threshold in the circuit just before the automation system.

Qr Control panel and incorporated receiver.

SPL Preheating board for operation with temperature lower than 5°C (optional).

S Key selector.

AL Blinker with tuned antenna and RG58 cable.

M Actuator.

E Electric lock.

Fte Pair of external photocells (transmitter).

Fre Pair of external photocells (receiver).

Fti Pair of internal photocells with CF posts.

Fri Pair of internal photocells with CF posts (receiver).

T 1-2-4 channel transmitter.

IMPORTANT: Before electrically activating the actuator, remove bleed screw "S" (fig. 17) which is positioned under the base with articulated joint and keep it for any later reuse. Only remove bleed screw "S" when the actuator is installed.

9) MANUAL OPENING

In emergency case, such as in the case of power cut-out, to release the gate, insert the same key C used for the adjustment of the by-pass valve inside the triangular pin (Fig.18) and rotate it counterclockwise.

The gate can now be opened manually.

WARNING! make sure that you manually push the gate open at the same speed as the motor would have.

To reset the electric operation of the actuator, turn the key in clockwise direction until pin is blocked.

9.1) Mod. ORO

In case of emergency, for example when the electrical power is disconnected, to release the gate, insert the same key C used for the adjustment of the by-pass valve inside the triangular pin (Fig. 18) and rotate it counterclockwise. The gate can now be opened manually. To reset the electric operation of the actuator, turn the key in clockwise direction until pin is blocked.

9.2) Mod. ORO/E

Since these models are reversible, for the manual operation of the gate it is sufficient that the electric lock be opened with the appropriate key. To make the manual manoeuvre easier, the lock can be released by means of a triangular pin which can be reached using the appropriate key.

10) PUSHING FORCE ADJUSTMENT

The pushing force is adjusted by two valves marked with the writing "Close" and "Open" respectively, which are used to adjust the closing and opening pushing force (fig.19).

Lift open the lid indicated in (Fig.19) there you will find the two valves.

Turn the valves towards the "+" sign to increase the force transmitted; turn the valves towards the "-" sign to reduce the force.

To achieve proper antisquash safety, the pushing force must be slightly higher than that needed to move the leaf during both closing and opening manoeuvres; the strength, which is measured on the leaf edge, must never exceed the limits set out by the current national standards.

Under no circumstances whatsoever must the by-pass valves be fully closed.

Complete the adjustments and restore the release system.

The actuator is not provided with electrical limit switches. Therefore the motors switch off at the end of the operation time set by the control unit. The said operation time must last approximately 2-3 seconds after the moment when the leaves meet the ground stop plates.

11) COVERING ELEMENT POSITIONING

Covering element "C" for all models can become left or right-handed by reversing the position of cap "T" (fig. 21), taking care to keep the water drainage channel always at the bottom, remember to screw back the Q screw.

12) AUTOMATION CHECK

Before the automation device finally becomes operational, scrupulously check the following conditions:

- Check that all components are tightly fixed.
- Check that all control devices (photocells, pneumatic edge etc) operate correctly.
- Check the emergency manoeuvre command.
- Check the opening and closing operations using the control devices provided.
- Check the normal (or personalised) function control logic in the control unit.

13) AUTOMATION OPERATION

Since the automation system can be remotely controlled by means of a radio control device or a Start button, all safety devices must be frequently checked in order to ensure their perfect efficiency.

In the event of any irregular operation, request immediate assistance from qualified personnel.

Children must be kept at a safe distance from the automation operation area.

14) CONTROL

Various types of controls are provided (manual, radio control, magnetic card access control etc.) depending on the installation requirements and characteristics.

(See the specific instructions for the various control systems).

The installer undertakes to instruct the user about the correct automation operation, and also point out the operations required in case of emergency.

15) MAINTENANCE

Before carrying out any maintenance to the controller, disconnect the system power supply.

- Periodically check the system for oil leaks.
To recap the oil, please use the same oil as described in the "**TECHNICAL SPECIFICATIONS**" paragraph and proceed with the following instruction:
 - a) With the piston all the way out take of the screw(P) situated on the base see (Fig.20).
 - b) Top up using the prescribed oil until its level reaches the level of the oil lid see (Fig.20).
 - c) Refit all the components paying attention to the seals.

ATTENTION - Replace the actuator oil every 2 years with the same oil as described in the "**TECHNICAL SPECIFICATIONS**" paragraph.

- Check all automation safety devices.
- When any operational malfunction is found, and not resolved, disconnect the system power supply and request the assistance of a qualified technician (installer).
- When the automation is out of order, activate the manual release knob to allow the manual opening and closing operations to be carried out by means of the electric lock.

16) MALFUNCTIONS AND REMEDIES**16.1) Faulty operation of the actuator**

Using an appropriate instrument, check that the ends of the actuator are supplied with voltage after the opening or closing command is given.

If the motor vibrates but does not turn, the causes could be as follows:

- Wrong connection of common wire C (always light blue).
- No connection between the drive capacitor and the two drive terminals.
- If the leaf movement is opposite to what it should be, reverse the motor drive connections in the control unit.

Leaf stops: when the operation time is insufficient, the leaves may not complete their strokes. In that case, slightly increase the operation time setting in the control unit.

16.2) Faulty operation of the electrical accessories

All faulty control and safety devices can cause abnormal operation or automation block.

If the control unit is provided with a self-diagnosing system, identify the fault.

In case of malfunction, it is advisable to disconnect and bridge all the automation devices one by one, if necessary, until the faulty device is identified. After replacing or repairing it, restore all the devices which were previously disconnected or bridged. For all devices installed, refer to their respective instruction manual.

WARNING! the above operation must be carried out by qualified personnel. During maintenance, the gate operational area must be appropriately indicated and closed off, in order to avoid any danger to persons, animals and property.

WARNINGS! Correct controller operation is only guaranteed when the data specified in this manual are respected. The company cannot be held responsible for any damage caused by failure to observe the standards on safety, installation and good technical practice, as well as the directives specified in the present manual.

17) SCRAPPING

WARNING: This operation should only be carried out by qualified personnel. Materials must be disposed of in conformity with the current regulations. In case of scrapping, the automation devices do not entail any particular risks or danger.

In case of recovered materials, these should be sorted out by type (electrical components, copper, aluminium, plastic etc.).

18) DISMANTLING

WARNING! This operation should only be carried out by qualified personnel. When the automation system is disassembled to be reassembled on another site, proceed as follows:

- Disconnect the power supply and the entire external electrical installation.
- Replace the bleed screw (fig. 17) under the articulated joint block.
- In the case where some of the components cannot be removed or are damaged, they must be replaced.

The descriptions and illustrations contained in the present manual are not binding. The Company reserves the right to make any alterations deemed appropriate for the technical, manufacturing and commercial improvement of the product, while leaving the essential product features.

Bft Spa

Via Lago di Vico, 44 ITALY
36015 Schio (VI)
T +39 0445 69 65 11
F +39 0445 69 65 22

→www.bft-automation.com

**SPAIN**

BFT GROUP ITALIBERICA DE AUTOMATISMOS S.L.
08401 Granollers - (Barcelona)
www.bftautomatismos.com

FRANCE

AUTOMATISMES BFT FRANCE
69800 Saint Priest
www.bft-france.com

GERMANY

BFT TORANTRIEBSSYSTEME GmbH
90522 Oberasbach
www.bft-torantriebe.de

UNITED KINGDOM

BFT AUTOMATION UK LTD
Heaton Mersey, Stockport SK4 3GL
www.bft.co.uk

IRELAND

BFT AUTOMATION LTD
Dublin 12

BENELUX

BFT BENELUX SA
1400 Nivelles
www.bftbenelux.be

POLAND

BFT POLSKA SP. Z O.O.
05-091 ZĄBKI
www.bft.pl

CROATIA

BFT ADRIA D.O.O.
51218 Drazice (Rijeka)
www.bft.hr

PORTUGAL

BFT SA-COMERCIO DE AUTOMATISMOS E MATERIAL DE SEGURANCIA
3026-901 Coimbra
www.bftportugal.com

CZECH REPUBLIC

BFT CZ S.R.O.
Praha
www.bft.it

TURKEY

BFT OTOMATIK KAPI SISTEMELERI SANAY VE
Istanbul
www.bftotomasyon.com.tr

RUSSIA

BFT RUSSIA
111020 Moscow
www.bftprus.ru

AUSTRALIA

BFT AUTOMATION AUSTRALIA PTY LTD
Wetherill Park (Sydney)
www.bftaustralia.com.au

U.S.A.

BFT USA
Boca Raton
www.bft-usa.com

CHINA

BFT CHINA
Shanghai 200072
www.bft-china.cn

UAE

BFT Middle East FZCO
Dubai